

ORDINANCE NO. _____

AN ORDINANCE OF THE CITY COUNCIL OF THE CITY OF ALLEN, COLLIN COUNTY, TEXAS, AMENDING THE ALLEN LAND DEVELOPMENT CODE BY AMENDING IN ITS ENTIRETY ARTICLE III, "BUILDING REGULATIONS" BY ADOPTING THE INTERNATIONAL BUILDING CODE, 2018 EDITION, WITH AMENDMENTS; INTERNATIONAL EXISTING BUILDING CODE, 2018 EDITION, WITH AMENDMENTS; INTERNATIONAL FIRE CODE, 2018 EDITION, WITH AMENDMENTS; INTERNATIONAL RESIDENTIAL CODE, 2018 EDITION, WITH AMENDMENTS; INTERNATIONAL MECHANICAL CODE, 2018 EDITION, WITH AMENDMENTS; INTERNATIONAL PLUMBING CODE, 2018 EDITION, WITH AMENDMENTS; INTERNATIONAL FUEL GAS CODE, 2018 EDITION, WITH AMENDMENTS; NATIONAL ELECTRICAL CODE, 2017 EDITION, WITH AMENDMENTS; INTERNATIONAL ENERGY CONSERVATION CODE, 2018 EDITION, WITH AMENDMENTS; PROVIDING A SEVERABILITY CLAUSE; PROVIDING A SAVINGS CLAUSE; PROVIDING A PENALTY OF FINE NOT TO EXCEED THE SUM OF TWO THOUSAND DOLLARS (\$2,000); AND PROVIDING FOR AN EFFECTIVE DATE.

WHEREAS, the International Code Council (ICC) has developed a set of comprehensive and coordinated national model construction codes (known generally as the "International Codes"); and,

WHEREAS, the National Fire Protection Association (NFPA) has developed a national model electrical code; and,

WHEREAS, the City of Allen has been involved throughout the development process of the International Codes and the National Electrical Code through participation with the North Texas Chapter of the International Code Council and through the regional review process by the Regional Codes Coordinating Committee of the North Central Texas Council of Governments (NCTCOG); and,

WHEREAS, the creation of the 2018 editions of the International Codes by the ICC and the 2017 edition of the National Electrical Code was in conjunction with the International Conference of Building Officials (ICBO), the organization whose codes the City of Allen has adopted for many years; and,

WHEREAS, the International Codes and the National Electrical Code have been reviewed by the NCTCOG and City staff; and,

WHEREAS, the City's building and construction codes are intended to be updated periodically, with the 2018 editions of the International Codes and the 2017 edition of the National Electrical Code being the most current published building and construction codes for which local amendments have been developed; and,

WHEREAS, the City Council of the City of Allen has determined that it is in the best interest of the residents of the City of Allen to adopt the 2018 editions of the International Building Code and the 2017 edition of the National Electrical Code, as stated herein, as the minimum standards for the construction, use, occupancy and maintenance of buildings and structures within the City limits, as set forth herein, and to adopt local amendments to said codes in order to account for unique local practices and/or conditions relating to the design and construction of structures within the City.

NOW, THEREFORE, BE IT ORDAINED BY THE CITY COUNCIL OF THE CITY OF ALLEN, COLLIN COUNTY, TEXAS, THAT:

SECTION 1. The Allen Land Development Code of the City of Allen, Texas, be amended by amending Article III, Building Regulations, in its entirety, to read as follows:

**“ARTICLE III
BUILDING REGULATIONS**

Sec. 3.01. Adoption of building codes.

1. There is hereby adopted by the City for the purpose of establishing rules and regulations for the construction, alteration, removal, demolition, equipment, use and occupancy, location and maintenance of buildings and structures, within the City, including permits and penalties, the following model codes with amendments and authority to adopt policies thereto as set forth in this Article:
 - a. The 2018 edition of the *International Building Code*, as published by the International Code Council, except as it may be in conflict with the provisions of another ordinance of the city and as amended by Section 3.02.
 - b. The 2018 edition of the *International Existing Building Code*, as published by the International Code Council, except as it may be in conflict with the provisions of another ordinance of the city and as amended by Section 3.03.
 - c. The 2018 edition of the *International Fire Code*, as published by the International Code Council, except as it may be in conflict with the provisions of another ordinance of the city and as amended by Section 3.04.
 - d. The 2018 edition of the *International Residential Code*, as published by the International Code Council, except as it may be in conflict with the provisions of another ordinance of the city and as amended by Section 3.05.
 - e. The 2018 edition of the *International Mechanical Code*, as published by the International Code Council, except as it may be in conflict with the provisions of another ordinance of the city and as amended by Section 3.06.
 - f. The 2018 edition of the *International Fuel Gas Code*, as published by the International Code Council, except as it may be in conflict with the provisions of another ordinance of the city and as amended by Section 3.07.
 - g. The 2018 edition of the *International Plumbing Code*, as published by the International Code Council, except as it may be in conflict with the provisions of another ordinance of the city and as amended by Section 3.08.
 - h. The 2017 edition of the *National Electrical Code*, as published by the National Fire Protection Association, except as it may be in conflict with the provisions of any ordinance of the city and as amended by Section 3.09.
 - i. The 2018 edition of the *International Energy Conservation Code*, as published by the International Code Council, except as it may be in conflict with the provisions of another ordinance of the city and as amended by Section 3.10.
2. The codes adopted by reference in subsection (1) of this section are hereby amended as follows:
 - a. The following words, terms and phrases, when used in this section, shall have the meanings ascribed to them in this section, except where the context clearly indicates a different meaning.

“Permanent toilet facilities” means a room in an existing building (including a construction trailer) or in the building being constructed with a water closet installed in such room which conforms to the plumbing code and is continuously available to all workers involved in a construction project.

“Temporary toilet facilities” means a portable, fully enclosed, chemically sanitized toilet which is serviced and cleaned at least once each week.

- b. Every construction project requiring a permit within the city shall have adequate toilet facilities for workers associated with the project. The following shall be considered adequate facilities:

Residential construction projects: At least one permanent toilet facility shall be maintained in each subdivision for the employees or subcontractors of each builder holding a permit for a building in that subdivision. A toilet facility must be provided by each builder as long as the builder holds an active permit in the subdivision.

Sec. 3.02 Amendments to the International Building Code, 2018 edition.

The following amendments to the International Building Code, 2018 edition, as adopted pursuant to Section 3.01, are hereby adopted:

1. **Section 101.4 is amended to read as follows:**

101.4 Referenced codes. The other codes listed in Sections 101.4.1 through 101.4.8 and referenced elsewhere in this code, when specifically adopted, shall be considered part of the requirements of this code to the prescribed extent of each such reference. Whenever amendments have been adopted to the referenced codes and standards, each reference to said code and standard shall be considered to reference the amendments as well. Any reference to NFPA 70 or the ICC *Electrical Code* shall mean the Electrical Code as adopted.

2. **Section 101.4.8 is amended by adding the following:**

101.4.8 Electrical. The provisions of the Electrical Code shall apply to the installation of electrical systems, including alterations, repairs, replacement, equipment, appliances, fixtures, fittings and appurtenances thereto.

3. **Sections 103 and 103.1 are amended by replacing the phrase “Department of Building Safety” with the phrase “Building Inspections Department” where it appears.**

4. **Section [A]104.2.1 is amended by adding the following language after the phrase “Section 1612” in the last sentence:**

...104.10.1, and applicable provisions of Article V of the ALDC and the Code of Ordinance.

5. **Section 105.2 is amended to read as follows:**

105.2 Work exempt from permit. Exemptions from permit requirements of this code shall not be deemed to grant authorization for any work to be done in any manner in violation of the provisions of this code or any other laws or ordinances of this jurisdiction. Permits shall not be required for the following:

1. Water tanks supported directly upon grade if the capacity does not exceed 5,000 gallons (18,925 L) and the ratio of height to diameter or width does not exceed 2 to 1.

2. Sidewalks and driveways not more than 30 inches (762 mm) above adjacent grade, and not over any basement or story below and which are not part of an accessible route.
3. Shade cloth structures constructed for nursery or agricultural purposes and not including service systems.
4. Window awnings supported by an exterior wall of Group R-3, as applicable in Section 101.2, and Group U occupancies.

6. **Section 109.2 is amended by adding Section 109.2.1 to read as follows:**

Section 109.2.1; Plan Review Fees. When submittal documents are required by Section 109.1, a plan review fee shall be paid at the time of submitting the submittal documents for plan review. Said plan review fee shall be 25% of the building permit fee as established by resolution of the City Council from time to time. The plan review fees are in addition to the permit fees.

7. **Section 109 is amended by adding new Sections 109.7, 109.8, 109.8.1, 109.8.2, and 109.9 to read as follows:**

109.7 Re-inspection fee. A reinspection fee as established by resolution of the city council may be charged when:

1. The inspection called for is not ready when the inspector arrives.
2. No building address or permit card is clearly posted.
3. City approved plans are not on the job site available to the inspector.
4. The building is locked or work otherwise not available for inspection when called.
5. The job site is red-tagged twice for the same item.
6. The original red tag has been removed from the job site and/or,
7. Violations exist on the property including failure to maintain erosion control, trash control or tree protection.

Any re-inspection fees assessed shall be paid before any more inspections are made on that job site.

109.8 Work without permit.

109.8.1 Investigation. Whenever work for which a permit is required by this code has been commenced without first obtaining a permit, a special investigation shall be made before a permit may be issued for such work.

109.8.2 Fee. An investigation fee, in addition to the permit fee, shall be collected whether or not a permit is subsequently issued. The investigation fee shall be equal to the amount of the permit fee required by this code or the city fee schedule as applicable, the payment of such investigation fee shall not exempt the applicant from compliance with all other provisions of either this code or the technical codes nor from the penalty described by law.

109.9 Unauthorized cover up fee. Any work concealed without first obtaining the required inspection in violation of section 110 shall be assessed a fee established by the city fee schedule.

8. **Section 110.3.5 is amended by deleting the “Exception”.**
9. **Section 116.5 is amended by adding a new Section 116.5.1 to read as follows:**

116.5.1 Damage or renovations to existing structures. When a structure is renovated or is damaged to 50% of the gross floor area or if the value of the damage or renovation exceeds 50% of the value of the structure at the time of damage or renovation all requirements of this Code shall be complied with in any such repair, reconstruction, or renovation.

10. **Section 202 is amended by amending the definitions of “Ambulatory Care Facility,” “Atrium,” “High-Rise Building,” and “Special Inspector” to read as follows:**

AMBULATORY CARE FACILITY. Buildings or portions thereof used to provide medical, surgical, psychiatric, nursing or similar care on a less than 24-hour basis to individuals who are rendered incapable of self-preservation by the services provided. This group may include but not be limited to the following:

- Dialysis centers
- Sedation dentistry
- Surgery centers
- Colonic centers
- Psychiatric centers

ATRIUM. An opening connecting three or more stories... {Balance remains unchanged}

HIGH-RISE BUILDING. A building with an occupied floor located more than 55 feet (16 764 mm) above the lowest level of fire department vehicle access.

SPECIAL INSPECTOR. A qualified person employed or retained by an approved agency who shall prove to the satisfaction of the registered design professional in responsible charge and the Building Official as having the competence necessary to inspect a particular type of construction requiring special inspection.

11. **Section 202 is amended by adding new definitions for the phrases “Assisted Living Facilities,” and “Repair Garage” to read as follows:**

ASSISTED LIVING FACILITIES. A building or part thereof housing persons, on a 24-hour basis, who because of age, mental disability or other reasons, live in a supervised residential environment which provides personal care services. The occupants are capable of responding to an emergency situation without physical assistance from staff.

REPAIR GARAGE. A building, structure or portion thereof used for servicing or repairing motor vehicles. This occupancy shall also include garages involved in minor repair, modification and servicing of motor vehicles for items such as lube changes, inspections, windshield repair or replacement, shocks, minor part replacement and other such minor repairs

12. **Section 303.1.3; is amended by to read as follows:**

303.1.3 Associated with Group E occupancies. A room or space used for assembly purposes that is associated with a Group E occupancy is not considered a separate occupancy except when applying the assembly requirements of Chapter 10 and 11.

13. **Section 304.1 is amended to add the following to the list of occupancies, to read as follows:**

Fire stations
Police stations with detention facilities for 5 or less

14. **Section 307.1.1. Paragraph 4 is amended to read as follows:**

4. Cleaning establishments... (text unchanged) ...with Section 707 or 1-hour horizontal assemblies constructed in accordance with Section 711 or both. See also IFC Chapter 21, Dry Cleaning Plant.

Section 402.4.2.1 Tennant Separations is amended as follows:

Each tenant space shall be separated from other tenant spaces by a *fire partition* wall sheet rocked on both sides and complying with Section 708.

Exception:

Existing conditions shall be subject to field inspection and reviewed for Approval at that time.

15. **Section 403.1 is amended by amending paragraph 3 under “Exceptions” to read as follows:**

3. The open-air portion of a building with a Group A-5 occupancy in accordance with Section 303.6.

16. **Section 403.3.2 is amended to read as follows:**

[F]403.3.2 **Water supply to required fire pumps.** In buildings that are more than 120 feet (36.5 m) in building height, required fire pumps shall be supplied by connections to no fewer than two water mains located in different streets. Separate supply piping shall be provided between each connection to the water main and the pumps. Each connection and the supply piping between the connection and the pumps shall be sized to supply the flow and pressure required for the pumps to operate. (No change to exception)

17. **Section 403.3, is amended by deleting Paragraph 2 under “Exceptions.”**

18. **Section 404.5 is amended by deleting the paragraph titled “Exception.”**

19. **Section 406.3.5.1 is amended by adding the following sentence:**

A fire separation is not required between a Group R-2 and U carport provided that the carport is entirely open on all sides and that the distance between the two is at least 10 feet (3048 mm).

20. **Section 506.2 is amended by adding Section 506.2.2 to read as follows:**

506.2.2 Open space limits. Open space shall be either on the same lot or dedicated for public use and shall be accessed from a street or *approved fire lane*. In order to be considered as accessible, if not in direct contact with a street or fire lane, a minimum 10-foot wide pathway meeting fire department access from the street or *approved fire lane* shall be provided.

21. **Section 506.3.1 is amended by to read as follows:**

506.3.1 Minimum percentage of perimeter. To qualify for an area factor increase based on frontage, a building shall not have less than 25 percent of its perimeter on a public way or open space. In order to be considered as accessible, if not in direct contact with a street or fire lane, a minimum 10-foot wide pathway meeting fire department access from the street or approved fire lane shall be provided.

22. **Section 602.1.1 is amended by adding the following sentence to the end of the section:**

Where a building contains more than one distinct type of construction, the building shall comply with the most restrictive area, height, and stories for the lesser type of construction or be separated by fire walls.

23. **Section 708.4.2 is amended by amending paragraph 1 under “Exceptions” to read as follows:**

Exceptions:

1. Buildings equipped with an automatic sprinkler system installed throughout in accordance with Section 903.3.1.1, or in accordance with Section 903.3.1.2 provided that sprinkler protection is provided in the space between the top of the fire partition and the underside of the floor or roof sheathing, deck or slab above as required for systems complying with Section 903.3.1.1. Portions of buildings containing concealed spaces filled with noncombustible insulation as permitted for sprinkler omission shall not apply to this exception for draftstopping.

24. **Section 712.1.9 is amended by changing item 4 to read as follows:**

4. Is not open to a corridor in Group I and H occupancies.

25. **Section 718.3 is amended by adding a paragraph title “Exceptions” to read as follows:**

Exceptions: Buildings equipped throughout with an automatic sprinkler system in accordance with Section 903.3.1.1. and provided that in combustible construction, sprinkler protection is provided in the floor space.

26. **Section 901.6.1 is amended by adding Section 901.6.1.1, to read as follows:**

901.6.1.1 Standpipe Testing. Building owners/managers must maintain and test standpipe systems as per NFPA 25 requirements. The following additional requirements shall be applied to the testing that is required every 5 years.

1. The piping between the Fire Department Connection (FDC) and the standpipe shall be back flushed or inspected by approved camera when foreign material is present or when caps are missing, and also hydrostatically tested for all FDC’s on any type of standpipe system. Hydrostatic testing shall also be conducted in accordance with NFPA 25 requirements for the different types of standpipe systems.
2. For any manual (dry or wet) standpipe system not having an automatic water supply capable of flowing water through the standpipe, the tester shall connect hose from a fire hydrant or portable pumping system (as approved by the fire code official) to each FDC, and flow water through the standpipe system to the roof outlet to verify that each inlet connection functions properly. Confirm that there are no open hose valves prior to introducing water into a dry standpipe. There is no required pressure criteria at the outlet. Verify that check valves function properly and that there are no closed control valves on the system.
3. Any pressure relief, reducing, or control valves shall be tested in accordance with the requirements of NFPA 25. All hose valves shall be exercised.
4. If the FDC is not already provided with approved caps, the contractor shall install such caps for all FDC’s as required by the fire code official.

5. Upon successful completion of standpipe test, place a blue tag (as per Texas Administrative Code, Fire Sprinkler Rules for Inspection, Test and Maintenance Service (ITM) Tag) at the bottom of each standpipe riser in the building. The tag shall be check-marked as “Fifth Year” for Type of ITM, and the note on the back of the tag shall read “5 Year Standpipe Test” at a minimum.
6. The procedures required by Texas Administrative Code Fire Sprinkler Rules with regard to Yellow Tags and Red Tags or any deficiencies noted during the testing, including the required notification of the local Authority Having Jurisdiction (fire code official) shall be followed.
7. Additionally, records of the testing shall be maintained by the owner and contractor, if applicable, as required by the State Rules mentioned above and NFPA 25.
8. Standpipe system tests where water will be flowed external to the building shall not be conducted during freezing conditions or during the day prior to expected night time freezing conditions.
9. Contact the fire code official for requests to remove existing fire hose from Class II and III standpipe systems where employees are not trained in the utilization of this firefighting equipment. All standpipe hose valves must remain in place and be provided with an approved cap and chain when approval is given to remove hose by the fire code official.

27. **Section 903.1.1 is amended to read as follows:**

[F]**903.1.1 Alternative protection.** Alternative automatic fire-extinguishing systems complying with Section 904 shall be permitted in addition to automatic sprinkler protection where recognized by the applicable standard, or as approved by the fire code official.

28. **Section 903.2 is amended to read as follows:**

[F]**903.2 Where required.** *Approved automatic sprinkler systems* in new buildings and structures shall be provided in the locations described in Section 903.2.1 through 903.2.12. Automatic sprinklers shall not be installed in elevator machine rooms, elevator machine spaces, and elevator hoist ways, other than pits where such sprinklers would not necessitate shunt trip requirements under any circumstances. Storage shall not be allowed with the elevator machine room. Signage shall be provided at the entry doors to the elevator machine room indicating “ELEVATOR MACHINERY – NO STORAGE ALLOWED.”

29. **Section 903.2 is amended by deleted the paragraph titled “Exception”.**

30. **Section 903.2.9 is amended by adding Section 903.2.9.3, to read as follows:**

[F]**903.2.9.3 Self-service storage facility.** An *automatic sprinkler system* shall be installed throughout all self-service storage facilities.

31. **[F]Section 903.2.11.3 is amended to read as follows:**

903.2.11.3 Buildings over 35 feet in height. An automatic sprinkler system shall be installed throughout buildings that have one or more stories, other than penthouses in compliance with Section 1510 of the International Building Code, that is located 35 feet (10668 mm) or more above the lowest level of fire department vehicle access, measured to the finished floor.

Exception: Open parking structures in compliance with Section 406.5 of the International Building Code, having no other occupancies above the subject garage.

32. **Section 903.2.11 is amended by adding Sections 903.2.11.7, 903.2.11.8, and 903.2.11.9 to read as follows:**

903.2.11.7 High-piled combustible storage. For any building with a clear height exceeding 12 feet (4572 mm) see Chapter or 32 to determine if those provisions apply.

903.2.11.8 Spray booths and rooms. New and existing spray booths and spraying rooms shall be protected by an approved automatic fire-extinguishing system.

903.2.11.9 Buildings over 6,000 sq. ft. An automatic sprinkler system shall be installed throughout all buildings with a building area over 6,000 sq. ft. and in all existing buildings that are enlarged to be 6,000 sq. ft. or greater. For the purpose of this provision, fire walls shall not define separate buildings.

Exception: Open parking garages in compliance with Section 406.5 of the International Building Code.

33. **Section 903.3.1.1.1 is amended to read as follows**

[F]**903.3.1.1.1 Exempt locations.** When approved by the *fire code official*, automatic sprinklers shall not be required in the following rooms or areas where such . . . *{intervening text unchanged}* . . . because it is damp, of fire-resistance-rated construction or contains electrical equipment.

1. Any room where the application of water, or flame and water, constitutes a serious life or fire hazard.
2. Any room or space where sprinklers are considered undesirable because of the nature of the contents, when approved by the code official.
3. Generator and transformer rooms, under the direct control of a public utility, separated from the remainder of the building by walls and floor/ceiling or roof/ceiling assemblies having a fire-resistance rating of not less than 2 hours.
4. Elevator machine rooms, machinery spaces and hoist ways, other than pits where such sprinklers would not necessitate shunt trip requirements under any circumstances.
5. Elevator machine rooms, machinery spaces, and hoistways, other than pits where such sprinklers would not necessitate shunt trip requirements under any circumstances.

34. **Section 903.3.1.2 is amended by adding Section 903.3.1.2.3 to read as follows:**

[F]**903.3.1.2.3 Attached Garages and Attics.** Sprinkler protection is required in attached garages, and in the following attic spaces:

1. (Remainder Unchanged)
2. (Remainder Unchanged)
3. Attic spaces of buildings that are two or more stories in height above grade plane or above the lowest level of fire department vehicle access.

4. Group R-4, Condition 2 occupancy attics not required by item 1 or 3 to have sprinklers shall comply with one of the following; (Remainder Unchanged)

35. **Section 903.3.1.3 is amended to read as follows:**

[F] **903.3.1.3 NFPA 13D sprinkler systems.** *Automatic sprinkler systems* installed in one- and two-family dwellings; Group R-3; Group R-4 Condition 1 and townhouses shall be permitted to be installed throughout in accordance with NFPA 13D or in accordance with state law.

36. **Section 903.3.4 is amended by adding a new Section 903.3.1.4 to read as follows:**

[F]**903.3.1.4 Freeze protection.** Freeze protection systems for automatic fire sprinkler systems shall be in accordance with the requirements of the applicable referenced NFPA standard and this section.

903.3.1.4.1 Attics. Only dry-pipe, preaction, or listed automatic fire sprinkler systems shall be allowed to protect attic spaces.

Exception: Wet-pipe fire sprinkler systems shall be allowed to protect non-ventilated attic spaces where:

1. The attic sprinklers are supplied by a separate floor control valve assembly to allow ease of draining the attic system without impairing sprinklers throughout the rest of the building, and
2. Adequate heat shall be provided for freeze protection as per the applicable referenced NFPA standard, and
3. The attic space is a part of the building's thermal, or heat, envelope, such that insulation is provided at the roof deck, rather than at the ceiling level.

903.3.1.4.2 Heat trace/insulation. Heat trace/insulation shall only be allowed where approved by the fire code official for small sections of large diameter water-filled pipe.

37. **Section 903.3.5 is amended by adding the following sentence to the end of the section:**

Water supply as required for such systems shall be provided in conformance with the supply requirements of the respective standards; however, every water-based fire protection system shall be designed with a 10 psi safety factor. Reference Section 507.4 for additional design requirements.

38. **Section 903.4 is amended by adding the following paragraph after "Exceptions":**

Sprinkler and standpipe system water-flow detectors shall be provided for each floor tap to the sprinkler system and shall cause an alarm upon detection of water flow for more than 45 seconds. All control valves in the sprinkler and standpipe systems except for fire department hose connection valves shall be electrically supervised to initiate a supervisory signal at the central station upon tampering.

39. **Section 903.4.2 is amended by adding the following sentence at the end of the section:**

The alarm device required on the exterior of the building shall be weatherproof horn/strobe notification appliance with a minimum 75 candela strobe rating, installed as close as practicable to the fire department connection.

40. **Section 905.2 is amended to read as follows:**

905.2 Installation standard. Standpipe systems shall be installed in accordance with this section and NFPA 14. Manual dry standpipe systems shall be supervised with a minimum of 10 psig and a maximum of 40 psig air pressure with a high/low alarm.

41. **Section 905.3 is amended by adding Section 905.3.9, to read as follows:**

905.3.9 Building area. In buildings exceeding 10,000 square feet in area per story, and where any portion of the building's interior area is more than 200 feet (60960 mm) of travel, vertically and horizontally, from the nearest point of fire department vehicle access. Class I automatic wet or manual wet standpipes shall be provided.

Exceptions:

1. Automatic dry and semi-automatic standpipes are allowed as provided for in NFPA 14.
2. R-2 occupancies of four stories or less in height having no interior corridors.

42. **Section 905.4, Paragraphs 1, 3 and 5 are amended to read as follows:**

1. In every required exit stairway, a hose connection shall be provided for each story above and below grade plane. Hose connections shall be located at an intermediate landing between stories, unless otherwise approved by the fire code official.

3. In every exit passageway, at the entrance from the exit passageway to other areas of a building.

Exception: Where floor areas adjacent to an exit passageway are reachable from an exit stairway hose connection by a ... (remainder unchanged).

5. Where the roof has a slope less than four unit's vertical in 12 unit's horizontal (33.3-percent slope), each standpipe shall be provided with a two-way hose connection located to serve the roof or at the highest landing of an exit stairway with stair access to the roof provided in accordance with Section 1011.12.

43. **Section 905.4 is amended by adding a new Paragraph 7 to read as follows:**

7. When required by this Chapter, standpipe connections shall be placed adjacent to all required exits to the structure and at two hundred feet (200') intervals along major corridors thereafter, or as indicated by the fire code official.

44. **Section 905.9 is amended by adding the following paragraph after "Exceptions":**

Sprinkler and standpipe system water-flow detectors shall be provided for each floor tap to the sprinkler system and shall cause an alarm upon detection of water flow for more than 45 seconds. All control valves in the sprinkler and standpipe systems except for fire department hose connection valves shall be electrically supervised to initiate a supervisory signal at the central station upon tampering.

45. **Section 907.1 is amended by adding Section 907.1.4 to read as follows:**

907.1.4 Design standards. Where a new fire alarm system is installed, the devices shall be addressable. Fire alarm systems utilizing more than 20 smoke detectors shall have analog addressable.

46. **Section 907.2.1 is amended to read as follows:**

907.2.1 Group A. A manual fire alarm system that activates the occupant notification system in accordance with Section 907.5 shall be installed in Group A occupancies having an occupant load of 300 or more persons or more than 100 persons above or below the lowest level of exit discharge. Group A occupancies not separated from one another in accordance with 707.3.10 of the International Building Code shall be considered as a single occupancy for the purposes of applying this section. Portions of Group E occupancies occupied for assembly purposes shall be provided with a fire alarm system as required for the Group E occupancy.

Activation of fire alarm notification appliances shall:

1. Cause illumination of the means of egress with light of not less than 1 foot-candle (11 lux) at the walking surface level, and
2. Stop any conflicting or confusing sounds and visual distractions.

(“Exception” remains unchanged)

47. **Section 907.2.3 is amended by amending the first paragraph to read as follows:**

907.2.3 Group E. A manual fire alarm system that initiates the occupant notification signal utilizing an emergency voice/alarm communication system meeting the requirements of Section 907.5.2.2 and installed in accordance with Section 907.6 shall be installed in Group E educational occupancies. When *automatic sprinkler systems* or smoke detectors are installed, such systems or detectors shall be connected to the building fire alarm system. An approved smoke detection system shall be installed in Group E day care occupancies. Unless separated by a minimum of 100’ open space, all buildings, whether portable buildings or the main building, will be considered one building for alarm occupant load consideration and interconnection of alarm systems.

48. **Section 907.2.3 is amended by amending Paragraph 1 under “Exceptions” to read as follows:**

Exceptions:

1. A manual fire alarm system is not required in Group E educational and day care occupancies with an occupant load of less than 50 when provided with an approved automatic sprinkler system.
 - 1.1. Residential In-Home day care with not more than 12 children may use interconnected single station detectors in all habitable rooms. (For care of more than five children 2 1/2 or less years of age, see Section 907.2.6.)

49. **Section 907.2.10.1 is amended to read as follows:**

Section 907.2.10.1 Group R-1. Single- or multiple-station smoke alarms and carbon monoxide alarms shall be installed and maintained in all the following locations in Group R-1:

(Paragraph 1, 2, and 3 remain unchanged)

4. For new construction, an approved carbon monoxide alarm shall be installed outside of each separate sleeping area in the immediate vicinity of the bedrooms in dwelling units that have an attached garage or gas fired appliance.
5. Where work requiring a permit occurs in existing dwellings that have attached garages or gas fired appliances, carbon monoxide alarms shall be provided.

50. **Section 907.2.10.2 is amended to read as follows:**

Section 907.2.10.2 Groups R-2, R-3, R-4 and I-1. Single-or multiple-station smoke alarms and carbon monoxide alarms shall be installed and maintained in Groups R2, R-3, R-4 and I-1 regardless of occupant load at all the following locations:

(Paragraph 1, 2, and 3 remain unchanged)

4. For new construction, an approved carbon monoxide alarm shall be installed outside of each separate sleeping area in the immediate vicinity of the bedrooms in dwelling units that have an attached garage or gas fired appliances.
5. Where work requiring a permit occurs in existing dwellings that have attached garages or gas fired appliances carbon monoxide alarms shall be provided.

51. **Section 907.2.13 is amended by amending paragraph 2 under “Exceptions” to read as follows:**

3. Open air portions of buildings with an occupancy in Group A-5 in accordance with Section 303.1 of the International Building Code; however, this exception does not apply to accessory uses including but not limited to sky boxes, restaurants and similarly enclosed areas.

52. **Section 907.4.2 is amended by adding Section 907.4.2.7, to read as follows:**

907.4.2.7 Type. Manual alarm initiating devices shall be an approved double action type.

53. **Section 907.6.1 is amended by adding Section 907.6.1.1, to read as follows:**

907.6.1.1. Wiring installation. All fire alarm systems shall be installed in such a manner that a failure of any single initiating device or single open in an initiating circuit conductor will not interfere with the normal operation of other such devices. All signaling line circuits (SLC) shall be installed in such a way that a single open will not interfere with the operation of any addressable devices (Class A). Outgoing and return SLC conductors shall be installed in accordance with NFPA 72 requirements for Class A circuits and shall have a minimum of four feet separation horizontal and one-foot vertical between supply and return circuit conductors. The initiating device circuit (IDC) from a signaling line circuit interface device may be wired Class B, provided the distance from the interface device to the initiating device is ten feet or less.

54. **Section 907.6.3 is amended by deleting all four Exceptions.**

55. **Section 907.6.6 is amended by adding the following sentence at the end of the paragraph:**

See 907.6.6 for the required information transmitted to the supervising station.

56. **Sections 909.20.5 thru 909.20.6.3 are amended to read as follows:**

909.20.5 Stairway or ramp pressurization alternative. Where the building is equipped throughout with an automatic sprinkler system in accordance with Section 903.3.1.1 and the stair pressurization alternative is chosen for compliance with building code requirements for a smokeproof enclosure, interior exit stairways or ramps shall be pressurized to a minimum of 0.10 inches of water (25 Pa) and a maximum of 0.35 inches of water (87 Pa) in the shaft relative to the building measured with all interior exit stairway and ramp doors closed under maximum anticipated conditions of stack effect and wind effect. Such systems shall comply with Section 909, including the installation of a separate fire-fighter’s smoke control panel as per Section 909.16, and a smoke control permit shall be required from the Fire Department as per Section 105.7

[F]909.20.6 Ventilating equipment. The activation of ventilating equipment for the stair or ramp pressurization system shall be by smoke detectors installed at each floor level at an approved location at the entrance to the smokeproof enclosure. When the closing device for the stairway or ramp shaft and vestibule doors is activated by smoke detection or power failure, mechanical equipment shall activate and operate at the required performance levels. Smoke detectors shall be installed in accordance with Section 907.3.

[F]909.20.6.1 Ventilating Systems. Smokeproof enclosure ventilation systems shall be independent of other building ventilation systems. The equipment, control wiring, power wiring and ductwork shall comply with one of the following:

1. Equipment, control wiring, power wiring and ductwork shall be located exterior to the building and directly connected to the smokeproof enclosure or connected to the smokeproof by ductwork enclosed by not less than 2-hour fire barriers constructed in accordance with Section 707 of the building code or horizontal assemblies constructed in accordance with Section 711 of the building code, or both.
2. Equipment, control wiring, power wiring and ductwork shall be located within the smokeproof enclosure with intake or exhaust directly from and to the outside or through ductwork enclosed by not less than 2-hour constructed in accordance with Section 707 of the building code or horizontal assemblies constructed in accordance with Section 711 of the building code, or both.
3. Equipment, control wiring, power wiring and ductwork shall be located within the building if separated from the remainder of the building, including other mechanical equipment, by not less than 2-hour fire barriers constructed in accordance with Section 707 of the building code or horizontal assemblies constructed in accordance with Section 711 of the building code, or both.

Exceptions:

1. Control wiring and power wiring utilizing a 2-hour rated cable or cable system.
2. Where encased with not less than 2 inches (51 mm) of concrete.
3. Control wiring and power wiring protected by a listed electrical circuit protection system with a fire-resistance rating of not less than 2 hours.

909.20.6.2 Standby power. Mechanical vestibule and stairway and ramp shaft ventilation systems and automatic fire detection systems shall be provided with standby power in accordance with Section 2702 of the building code.

909.20.6.3 Acceptance and testing. Before the mechanical equipment is approved, the system shall be tested in the presence of the fire code official to confirm that the system is operating in compliance with these requirements.

57. **Section 910.2 is amended by amending paragraphs 2 and 3 under “Exceptions” to read as follows:**

2. Only manual smoke and heat removal shall be required in areas of buildings equipped with early suppression fast-response (ESFR) sprinklers. Automatic smoke and heat removal is prohibited.

3. Only manual smoke and heat removal shall be required in areas of buildings equipped with control mode special application sprinklers with a response time index of 50 (m•s)^{1/2} or less that are listed to control a fire in stored commodities with 12 or fewer sprinklers. Automatic smoke and heat removal is prohibited.

58. **Section 910.2 is amended by adding Sections 910.2.3 to read as follows:**

910.2.3 Group H. Buildings and portions thereof used as a Group H occupancy as follows:

1. In occupancies classified as Group H-2 or H-3, any of which are more than 15,000 square feet (1394 m²) in single floor area.

Exception: Buildings of noncombustible construction containing only noncombustible materials.

2. In areas of buildings in Group H used for storing Class 2, 3 and 4 liquid and solid oxidizers, Class 1 and unclassified detonable organic peroxides, Class 3 and 4 unstable (reactive) materials, or Class 2 or 3 water-reactive materials as required for a high-hazard commodity classification.

Exception: Buildings of noncombustible construction containing only noncombustible materials.

59. **Section 910.3 is amended by adding Section 910.3.4; to read as follows:**

910.3.4 Vent operation. Smoke and heat vents shall be capable of being operated by approved automatic and manual means. Automatic operation of smoke and heat vents shall conform to the provisions of Sections 910.3.2.1 thru 910.3.2.3

[F]**910.3.4.1. Sprinklered buildings.** Where installed in buildings equipped with an approved automatic sprinkler system, smoke and heat vents shall be designed to operate automatically. The automatic operating mechanism of the smoke and heat vents shall operate at a temperature rating at least 100 degrees F (approximately 38 degrees Celsius) greater than the temperature rating of the sprinklers installed.

Exception: Manual only system per Section 910.2.

[F]**910.3.4.2 Nonsprinklered buildings.** Where installed in buildings not equipped with an approved automatic sprinkler system, smoke and heat vents shall operate automatically by actuation of a heat-responsive device rated at between 100°F (56°C) and 220°F (122°C) above ambient.

Exception: Listed gravity-operated drop out vents.

60. **Section 910.4.3.1 is amended to read as follows:**

[F]**Section 910.4.3.1 Makeup air.** Makeup air openings shall be provided within 6 feet (1829 mm) of the floor level. Operation of makeup air openings shall be automatic. The minimum gross area of makeup air inlets shall be 8 square feet per 1,000 cubic feet per minute (0.74 m² per 0.4719 m³/s) of smoke exhaust.

61. **Section 910.4.4 is amended to read as follows:**

(F)**Section 910.4.4 Activation.** The mechanical smoke removal system shall be activated automatically by the automatic sprinkler system or by an approved fire detection system. Individual manual controls shall also be provided.

Exception: Manual only systems per Section 910.2.

62. **Section 912.2 is amended by adding Section 912.2.3 to read as follows:**

[F]**912.2.3 Hydrant distance.** An approved fire hydrant shall be located within 100 feet of the fire department connection as the fire hose lays along an unobstructed path.

63. **Section 913.2.1 is amended by adding Section 913.2.1.1 with Exception to read as follows:**

Section 913.2.1.1 Fire Pump Room Access. When located on the ground level at an exterior wall, the fire pump room shall be provided with an exterior fire department access door that is not less than 3 ft. in width and 6 ft. – 8 in. in height, regardless of any interior doors that are provided. A key box shall be provided at this door, as required by IFC Section 506.1.

Exception: When it is necessary to locate the fire pump room on other levels or not at an exterior wall, the corridor leading to the fire pump room access from the exterior of the building shall be provided with equivalent fire resistance as that required for the pump room, or as approved by the Fire Code official. Access keys shall be provided in the key box as required by Section 506.1

64. **Section 913.4 is amended by adding the following sentence at the end of the section:**

The fire-pump system shall also be supervised for “loss of power,” “phase reversal,” and “pump running” conditions by supervisory signal on district circuits.

65. **Section 1006.2.2 is amended by adding Section 1006.2.2.7 to read as follows:**

1006.2.2.7 Electrical rooms. For electrical rooms, special exiting requirements may apply. Reference the Electrical Code as adopted.

66. **Section 1009.1 is amended by adding a new paragraph 4 under “Exceptions”:**

4. Buildings regulated under State law and built in accordance with State registered plans, including any variances or waivers granted by the State, shall be deemed to be in compliance with the requirements of Section 1009.

67. **Section 1009.8 is amended by adding Exception 7 to read as follows:**

7. Buildings regulated under State Law and built in accordance with State registered plans, including variances or waivers granted by the State, shall be deemed to be in compliance with the requirements of Section 1009 and Chapter 11.

68. **Section 1010.1.9.5 is amend by amending Exceptions 3 and 4 to read as follows:**

3. Where a pair of doors serves an occupant load of less than 50 persons in a Group B, F, M or S occupancy... *{Remainder unchanged}*.

4. Where a pair of doors serves a Group A B, F, M or S occupancy. *{Remainder unchanged}*

69. **Section 1015.8 is amended to read as follows:**

1. Operable windows where the top of the sill of the opening is located more than 55 feet (16764 mm) above the finished grade or other surface below and that are provided with window fall prevention devices that comply with ASTM F2006.
70. **Section 1020.1 is amended by adding Exception 6 to read as follows:**
 6. In Group B occupancies, corridor walls and ceilings need not be of fire-resistive construction within a single tenant space when the space is equipped with approved automatic smoke-detection within the corridor. The actuation of any detector shall activate self-annunciating alarms audible in all areas within the corridor. Smoke detectors shall be connected to an approved automatic fire alarm system where such system is provided.
71. **Section 1020.6 is amended to read as follows:**

1020.6 Corridor continuity. All corridors shall be continuous from the point of entry to an exit and shall not be interrupted by intervening rooms.
72. **Section 1029.1.1.1 is deleted.**
73. **Section 1101.1 is amended by adding an “Exception” to read as follows:**

Exception: Components of projects regulated by and registered with Architectural Barriers Division of Texas Department of Licensing and Regulation shall be deemed to be in compliance with the requirements of this chapter.
74. **Table 1505.1 is amended by amending footnote “b” to read as follows and deleting footnote “c”:**
 - b. Non-classified roof coverings shall be permitted on buildings of U occupancies having not more than 120 sq. ft. of projected roof area. When exceeding 120 sq. ft. of projected roof area, buildings of U occupancies may use non-rated non-combustible roof coverings.
75. **Section 1510.1 is amended by amending the first paragraph to read as follows:**

1510.1 General. Materials and methods of applications used for recovering or replacing an existing roof covering shall comply with the requirements of Chapter 15. All individual replacement shingles shall be in compliance with the rating required by Table 1505.1.

{Exception text unchanged}
76. **Section 2211.1 is amended by adding paragraph 5 to read as follows:**
 - 5 All framed walls top plates must be braced and supported by structural members to ceiling steel or roof at 6’ (foot) on center spacing. (Lay in grid is not a structural support).
77. **Section 2308.5.8 is amended by amending the first sentence to read as follows:**

2308.5.8 Pipes in walls. Stud partitions containing plumbing, heating or other pipes 2 inches and larger shall be installed in a 2”x 6” stud wall and top/bottom plates and the joist underneath spaced to provide proper clearance for the piping. *{remainder of text unchanged}*
78. **Section 2901.1 is amended by adding the following sentences:**

The provisions of this Chapter are meant to work in coordination with the provisions of Chapter 4 of the International Plumbing Code. Should any conflicts arise between the two chapters, the Building Official shall determine which provision applies.

79. **Section 2902.1 is amended by adding the following sentence:**

In other than E Occupancies, the minimum number of fixtures in Table 2902.1 may be requested in writing, by the applicant stating reasons for a reduced number and approved by the Building Official.

80. **Section 2902.1 is amended by adding footnote “g” to read as follows:**

g. Drinking fountains are not required in M Occupancies with an occupant load of 100 or less, B Occupancies with an occupant load of 25 or less, and for dining and/or drinking establishments.

81. **Section 2902.1 is amended by adding Section 2902.1.4 to read as follows:**

2902.1.4 Additional fixtures for food preparation facilities. In addition to the fixtures required in the Chapter, all food service facilities shall be provided with additional fixtures set out in this section.

2902.1.4.1 Hand washing lavatory. At least one hand washing lavatory shall be provided for use by employees that is accessible from food preparation, food dispensing and ware washing areas. Additional hand washing lavatories may be required based on convenience of use by employees.

2902.1.4.2 Service sink. In new or remodeled food service establishments, at least one service sink or one floor sink shall be provided so that it is conveniently located for the cleaning of mops or similar wet floor cleaning tool and for the disposal of mop water and similar liquid waste. The location of the service sink(s) and/or mop sink(s) shall be approved by the Building Official or health department.

82. **Section 3001.2 is deleted.**

83. **Section 3002.1 is amended by adding Exceptions 4 and 5 to read as follows:**

4. Elevators completely located within atriums shall not require hoist way enclosure protection.
5. Elevators in open or enclosed parking garages that serve only the parking garage, shall not require hoistway enclosure protection.

84. **Section 3005.4 is amended to read in its entirety as follows:**

Section 3005.4 Machine rooms, control rooms, machinery spaces and control spaces

Elevator machine rooms, control rooms, control spaces and machinery spaces shall be enclosed with *fire barriers* constructed in accordance with Section 707 or *horizontal assemblies* constructed in accordance with Section 711, or both. The *fire-resistance rating* shall be not less than the required rating of the hoistway enclosure served by the machinery. Openings in the *fire barriers* shall be protected with assemblies having a *fire protection rating* not less than required for the hoistway enclosure door.

Exceptions:

1. Elevator machine rooms, control rooms, machinery spaces and control spaces completely located within atriums shall not require enclosure protection.

2. Elevator machine rooms, control rooms, machinery spaces and control spaces in open or enclosed parking garages that serve only the parking garage, shall not require enclosure protection.

85. **Section 3005 is amended by adding Section 3005.7 and Section 3005.8 to read as follows:**

3005.7 Fire protection in machine rooms, control rooms, machinery spaces and control spaces.

3005.7.1 Automatic sprinkler system. The building shall be equipped throughout with an automatic sprinkler system in accordance with Section 903.3.1.1, except as otherwise permitted by Section 903.3.1.1.1 and as prohibited by Section 3005.7.2.1.

3005.7.2.1 Prohibited locations. Automatic sprinkler shall not be installed in machine rooms, elevator machinery spaces, control rooms, control spaces and elevator hoistways.

3005.7.2.2 Sprinkler system monitoring. The sprinkler system shall have a sprinkler control valve supervisory switch and water flow initiating device provided for each floor that is monitored by the building's fire alarm system.

3005.7.3 Water protection. An approved method to prevent water from infiltrating into the hoistway enclosure from the operation of the automatic sprinkler system outside the elevator lobby shall be provided.

3005.7.4 Shunt trip. Means for elevator shutdown in accordance with Section 3005.5 shall not be installed.

3005.8 Storage. Storage shall not be allowed within the elevator machine room, control room, machinery spaces and/or control spaces. Provide approved signage at each entry to the above listed locations stating: "No Storage Allowed."

86. **Section 3006.2 is amended by amending paragraph 5 to read as follows**

5. The building is a high rise and the elevator hoist way is more than 55 feet (16764 mm) in height. The height of the hoist way shall be measured from the lowest floor at or above grade to the highest floors served by the hoist way.

Sec. 3.03 Amendments to the International Existing Building Code, 2018 edition.

The following amendments to the International Existing Building Code, 2018 edition, as adopted pursuant to Section 3.01, are hereby adopted:

1. **Section 102.4 is amended to read as follows:**

[A]102.4 Referenced codes and standards. The codes, when specifically adopted, and standards referenced in this code shall be considered part of the requirements of this code to the prescribed extent of each such reference and as further regulated in Sections 102.4.1 and 102.4.2.

2. **Section 202 is amended by amending the definitions of "Existing Building" and "Existing Structure" to read as follows:**

Existing Building - A building, structure, or space, with an approved final inspection issued under a code edition which is at least 2 published code editions preceding the currently adopted building code; or a change of occupancy.

Existing Structure- A building, structure, or space, with an approved final inspection issued under a code edition which is at least 2 published code editions preceding the currently adopted building code; or a change of occupancy.

3. **Section 305.1 is amended by adding a paragraph titled “Exception” to read as follows:**

Exception: Components of projects regulated by and registered with Architectural Barriers Division of Texas Department of Licensing and Regulation shall be deemed to be in compliance with the requirements of this chapter.

4. **Section 305.4.2 is amended by adding Item Number 7 to read as follows:**

7. At least one accessible family or assisted use toilet room shall be provided in accordance with Chapter 11 of the International Building Code.

5. **Section 401.3 is deleted.**

6. **Section 405.2.5 is deleted.**

7. **Section 406.1 is amended to read as follows:**

406.1 Material. Existing electrical wiring and equipment undergoing repair shall be allowed to be or replaced with like material, in accordance with the requirements of NFPA 70.

8. **Section 502.3 is deleted.**

9. **Section 504.1.2 is amended to read as follows:**

504.1.2 Existing fire escapes. Existing fire escapes shall continue to be accepted as a component in the means of egress in existing buildings only. Existing fire escapes shall be permitted to be repaired or replaced.

10. **Section 504.1.3 is deleted.**

11. **Section 507.3 is deleted.**

12. **Section 701.3 is deleted.**

13. **Section 702.6 is amended to read as follows:**

702.6 Materials and methods. All new work shall comply with the materials and methods requirements in the *International Building Code*, *International Energy Conservation Code*, *International Mechanical Code*, *National Electrical Code*, *International Fuel Gas Code*, and *International Plumbing Code*, as applicable, that specify material standards, detail of installation and connection, joints, penetrations, and continuity of any element, component, or system in the building.

14. **Section 802.5.1 is amended to read as follows:**

802.5.1 Minimum requirement. Every portion of open-sided walking surfaces, including mezzanines, equipment platforms, aisles, stairs, ramps and landings that are not provided with guards, or those in which the existing guards are judged to be in danger of collapsing, shall be provided with guards.

15. **Section 803.1 is amended by adding the following sentence:**

For the purpose of fire sprinkler protection and fire alarm requirements included in this section, the work area shall be extended to include at least the entire tenant space or spaces bounded by walls capable of resisting the passage of smoke containing the subject work area, and if the work area includes a corridor, hallway, or other exit access, then such corridor, hallway, or other exit access shall be protected in its entirety on that particular floor level.

16. **Section 803.2.4 is amended by amending the paragraph titled “Exception” to read as follows:**

Exception: Supervision is not required where the Fire Code does not require such for new construction.

17. **Section 803.3 is amended to read in its entirety as follows:**

803.3 Standpipes. Refer to Section 1103.6 of the Fire Code for retroactive standpipe requirements.

18. **Section 805.2 is amended by deleting Exception 1.**

19. **Section 805.3.1.2 is amended to read as follows:**

805.3.1.2 Fire escapes required. For other than Group 1-2, where more than one exit is required an existing fire escape complying with Section 805.3.1.2.1 shall be accepted as providing one of the required means of egress.

20. **Section 805.3.1.2.1 is amended as follows:**

- A. **Numbered paragraph 2 is amended to read as follows:**

2. Access to a fire escape shall be through a door.

- B. **Numbered paragraph 3 is deleted.**

- C. **Numbered paragraph 5 is amended to read as follows:**

5. In all building of Group E occupancy up to and including the 12th grade, building of Group I occupancy, boarding houses, and childcare centers, ladders of any type are prohibited on fire escapes used as a required means of egress.

21. **Section 805.5.2 Transoms is amended to read as follows:**

805.5.2 Transoms. In all buildings of Group B, E, ...*{remainder unchanged}*.

22. **Section 904.1 is amended by adding the following sentence:**

For the purpose of fire sprinkler protection and fire alarm requirements included in this section, the work area shall be extended to include at least the entire tenant space or spaces bounded by walls containing the subject work area, and if the work area includes a corridor, hallway, or other exit access, then such corridor, hallway, or other exit access shall be protected in its entirety on that particular floor level.

23. **Section 904.1.1 is amended to read as follows:**

904.1.1 High-rise buildings. An automatic sprinkler system shall be provided in work areas of high-rise buildings.

24. **Section 1103.3 is deleted.**

25. **Section 1201.4 is deleted.**

26. **Section 1301.3.2 is amended to read as follows:**

1301.3.2 Compliance with other codes. Buildings that are evaluated in accordance with this section shall comply with the *International Fire Code*.

27. **Section 1301.3.3 is deleted.**

28. **Section 1402.6 is deleted.**

Sec. 3.04. Amendments to the International Fire Code, 2018 edition.

The following amendments to the International Fire Code, 2018 edition, as adopted pursuant to Section 3.01, are hereby adopted:

1. **Section 102.1 is amended by amending Item 3 to read as follows:**

3. Existing structures, facilities and conditions when required in Chapter 11 or in specific Sections of this code.

2. **Sections 103.1, and 103.2 are amended to read as follows:**

103.1 General. The Fire Code shall be enforced by the Division of Fire Prevention. The Division of Fire Prevention is hereby established as a division of the Fire Department of the City of Allen and shall operate under the supervision of the Chief of the Fire Department.

103.2 Appointment. The Assistant Fire Chief of Prevention is in charge of the Division of Fire Prevention and shall be appointed by the Fire Chief on the basis of proper qualification. . . . *{remainder of Section unchanged}*

3. **Section 104.1 is amended by adding Section 104.1.1 to read as follows:**

104.1.1 Code Official. For the purpose of this code, "Code Official" shall mean the Fire Chief or his designated representative(s).

4. **Section 105.1 is amended by adding Section 105.1.7 to read as follows:**

105.1.7 Failure to obtain permit or working without a permit. Any person who fails to obtain a permit or is conducting work without a permit approved by the Allen Fire Department shall be liable to a fee of two (2) times the required permit fee figured in accordance with the fee schedule adopted by resolution of the city council. A minimum fee of one-hundred twenty dollars (\$120.00) in addition to the required permit fee will be assessed. Working without a permit shall include non-compliance of Sections 105.3.5 and 105.4.6.

5. **Section 105.2.3 is amended by adding Section 105.2.3.1 as follows:**

105.2.3.1 Time limitation of application. Reinstatement of expired permits will require the applicant to resubmit permit application and required documents and shall be liable for applicable permit fees.

6. **Section 105.3.3 is amended to read as follows:**

105.3.3 Occupancy Prohibited before Approval. The building or structure shall not be occupied prior to the Fire Code Official issuing a permit, when required, and conducting associated inspections

indicating the applicable provisions of this code have been met. No building or structure shall be used or occupied, and no change in the existing occupancy classification of a building or structure or portion thereof shall be made, until the Building Official has issued a Certificate of Occupancy.

7. **Section 105.4.6 is amended to read as follows:**

105.4.6 Retention of construction documents. One set of construction documents shall be retained by the Fire Code Official until final approval of the work covered therein. One set of approved construction documents shall be returned to the applicant, and said set, along with the Fire Department Permit, shall be kept on site of the building or work at all times during which the work authorized thereby is in progress. Construction documents shall be retained by the installing company as required by the Texas State Fire Marshal's Office, after final approval of work covered therein.

8. **Section 105.7 is amended to read as follows:**

105.7 Required construction permits. The code official is authorized to issue construction permits for work set forth in Sections 105.7.1 to 105.7.26.

9. **Section 105.7.12 is amended to read as follows:**

105.7.12 Gates and barricades across fire apparatus access roads. A construction permit shall be required to install any system that during normal operation delays or prevents entry to, or obstructs a fire lane or street into, the premises of a residential or commercial area.

10. **Section 105.7 is amended by adding Section 105.7.26 to read as follows:**

105.7.26 Electronic access control systems. Construction permits are required for the installation or modification of an electronic access control system, as specified in Chapter 10. A separate construction permit is required for the installation or modification of a fire alarm system that may be connected to the access control system. Maintenance performed in accordance with this code is not considered a modification and does not require a permit.

11. **Section 105 is amended by adding Section 105.8 to read as follows:**

105.8 Permit and other fees. Fees for each permit required, plan reviews, inspections, re-inspections, other regulatory storage/handling, and equipment use or process established by resolution of the city council from time to time and made a part of the City's Fee Schedule shall be paid prior to the issuance of such permit, performance of such service, or use of such equipment.

12. **Section 106.2 is amended by adding Section 106.2.3 to read as follows:**

106.2.3 Inspection of existing premises. The Fire Chief, or designated representative, shall inspect all buildings, premises, or portion thereof as often as may be necessary. An initial inspection and one (1) re-inspection shall be made free of charge. If the Fire Chief or his designee is required to make follow-up inspections after the initial inspection and re-inspection to determine whether a violation or violations observed during the previous inspection have been corrected, a fee shall be charged. The occupant, lessee, or person making use of the building or premises shall pay said fee or fees within thirty (30) days of being billed as a condition to continue lawful occupancy of the building or premises.

Fees for follow-up inspections after initial and re-inspection shall be as set forth in the fee schedule as adopted by resolution of the city council.

Recurring violations from year to year will result in issuance of a citation and shall not be restricted to the inspection and re-inspection procedure as indicated in this Section.

13. **Section 110.4 is amended to read as follows:**

110.4 Violation Penalties. Any person, firm, or corporation violating any of the provisions or terms of this Article or Code adopted herein or shall fail to comply with any of the requirements thereof or who shall erect, install, alter, repair or do work in violation of the approved construction documents or directive of the fire code official, or of a permit or certificate used under the provisions of this code shall be guilty of a misdemeanor and, upon conviction in the Municipal Court of the City of Allen, shall be subject to a fine not to exceed two thousand and no/100 dollars (\$2,000.00) for each offense. Each and every day any such violation shall continue shall be deemed to constitute a separate offense.

14. **Section 112.4 is amended to read as follows:**

111.4 Failure to comply. Any person who shall continue any work after having been served with a stop work order, except such work as that person is directed to perform to remove a violation or unsafe condition, shall be liable to a fine of not more than two thousand and no/100 (\$2,000.00) dollars for each offense, and each and every day such violation shall continue shall be deemed to constitute a separate offense.

15. **Section 202 is amended by adding definitions for the phrases "ADDRESSABLE FIRE DETECTION SYSTEM," "ANALOG ADDRESSABLE FIRE DETECTION SYSTEM," "DEFENDING IN PLACE," "SELF-SERVICE STORAGE FACILITY," "STANDBY PERSONNEL," and "UPGRADED OR REPLACED FIRE ALARM SYSTEM" to read as follows:**

ADDRESSABLE FIRE DETECTION SYSTEM. Any system capable of providing identification of each individual alarm-initiating device. The identification shall be in plain English and as descriptive as possible to specifically identify the location of the device in alarm. The system shall have the capability of alarm verification.

ANALOG ADDRESSABLE FIRE DETECTION SYSTEM. Any system capable of calculating a change in value by directly measurable quantities (voltage, resistance, etc.) at the sensing point. The physical analog may be conducted at the sensing point or at the main control panel. The system shall be capable of compensating for long-term changes in sensor response while maintaining a constant sensitivity. The compensation shall have a preset point at which a detector maintenance signal shall be transmitted to the control panel. The sensor shall remain capable of detecting and transmitting an alarm while in maintenance alert.

DEFEND IN PLACE. A method of emergency response that engages building components and trained staff to provide occupant safety during an emergency. Emergency response involves remaining in place, relocating within the building, or both, without evacuating the building.

SELF-SERVICE STORAGE FACILITY. Real property designed and used for the purpose of renting or leasing individual storage spaces to customers for the purpose of storing and removing personal property on a self-service basis.

STANDBY PERSONNEL. Qualified fire service personnel approved by the Fire Chief. When utilized, the number required shall be as directed by the Fire Chief. Charges for utilization shall be as normally calculated by the jurisdiction.

UPGRADED OR REPLACED FIRE ALARM SYSTEM. A fire alarm system that is upgraded or replaced includes, but is not limited to the following:

1. Replacing one single board or fire alarm control unit component with a newer model

2. Installing a new fire alarm control unit in addition to or in place of an existing one
3. Conversion from a horn system to an emergency voice/alarm communication system
4. Conversion from a conventional system to one that utilizes addressable or analog devices
5. Replacing boards of the same model with chips utilizing the same or newer firmware

The following are not considered an upgrade or replacement:

1. Firmware updates
2. Software updates

16. **Section 202 is amended by amending the definitions of "AMBULATORY HEALTH CARE FACILITY," "ATRIUM," "FIRE WATCH," "FIREWORKS," "HIGH-PILED COMBUSTIBLE STORAGE," "HIGH RISE BUILDING," AND "REPAIR GARAGE" to read as follows:**

AMBULATORY HEALTH CARE FACILITY. Buildings or portions thereof used to provide medical, surgical, psychiatric, nursing, or similar care on a less than 24-hour basis to individuals who are rendered incapable of self-preservation. This group may include but not be limited to the following:

- a. Dialysis centers
- b. Procedures involving sedation
- c. Sedation dentistry
- d. Surgery centers
- e. Colonic centers
- f. Psychiatric centers

ATRIUM. An opening connecting three or more stories ... *{remaining text unchanged}*

FIRE WATCH. A temporary measure intended to ensure continuous and systematic surveillance of a building or portion thereof by one or more qualified individuals or standby personnel when required by the Fire Code Official, for the purposes of identifying and controlling fire hazards, detecting early signs of unwanted fire, raising an alarm of fire and notifying the Fire Department.

FIREWORKS. Any composition or device for the purpose of producing a visible or an audible effect for entertainment purposes by combustion, deflagration, or detonation, and/or activated by ignition with a match or other heat producing device that meets the definition of 1.4G fireworks or 1.3G fireworks as set forth herein. ... *{remainder of text unchanged}*

HIGH-PILED COMBUSTIBLE STORAGE : *add a second paragraph to read as follows :* Any building or portion of building used for storage classified as a group S Occupancy or Speculative Building exceeding 6,000 sq. ft. that has a clear height in excess of 14 feet, making it possible to be used for storage in excess of 12 feet, shall be considered to be high-piled storage. When a specific product cannot be identified, a fire protection system and life safety features shall be installed as for Class IV commodities, to the maximum pile height.

HIGH-RISE BUILDING. A building with an occupied floor located more than 55 feet (16,764 mm) above the lowest level of Fire Department vehicle access.

REPAIR GARAGE. A building, structure or portion thereof used for servicing or repairing motor vehicles. This occupancy shall also include garages involved in minor repair, modification and servicing of motor vehicles for items such as lube changes, inspections, windshield repair or replacement, shocks, minor part replacement, and other such minor repairs.

17. **Section 307.1.1 is amended to read as follows:**

307.1.1 Prohibited Open Burning. Open burning that is offensive or objectionable because of smoke or emissions or when atmospheric conditions or local circumstances make such fires hazardous shall be prohibited.

Exception: {*No change.*}

18. **Section 307.2 is amended to read as follows:**

307.2 Permit required. A permit shall be obtained from the Fire Code Official in accordance with Section 105.6 prior to kindling a fire for recognized silvicultural, range, or wildlife management practices, prevention or control of disease or pests, or open burning. Application for such approval shall only be presented by, and permits issued to the owner of, the land upon which the fire is to be kindled.

Examples of state, local law, or regulations referenced elsewhere in this Section may include but not be limited to the following:

1. Texas Commission on Environmental Quality (TCEQ) guidelines and/or restrictions.
2. State, County, or Local temporary or permanent bans on open burning.
3. Local written policies as established by the Fire Code Official.

19. **Section 307.3 is amended to read as follows:**

307.3 Extinguishing Authority. The fire code official is authorized to order the extinguishment by the permit holder, another person responsible or the fire department of open burning that creates or adds to a hazardous or objectionable situation.

20. **Section 307.4 is amended to read as follows:**

307.4 Location. The location for open burning shall not be less than 300 feet (91,440 mm) from any structure, and provisions shall be made to prevent the fire from spreading to within 300 feet (91,440 mm) of any structure.

Exceptions: {*No change*}

21. **Section 307.4.3 is amended by adding a new paragraph 2 under “Exceptions” to read as follows:**

2. Where buildings, balconies, and decks are protected by an approved automatic sprinkler system.

22. **Section 307.4 is amended by adding Sections 307.4.4 and 307.4.5 to read as follows:**

307.4.4 Permanent Outdoor Firepit. Permanently installed outdoor firepits for recreational fire purposes shall not be installed within 10 feet of a structure or combustible material.

Exception: Permanently installed outdoor fireplaces constructed in accordance with the International Building Code.

307.4.5 Trench Burns. Trench burns shall be conducted in air curtain trenches and in accordance with Section 307.2.

23. **Section 307.5 is amended to read as follows:**

307.5 Attendance. Open burning, trench burns, bonfires, or recreational fires and use of portable outdoor fireplaces shall be constantly attended until the . . . {remainder of Section unchanged}

24. **Section 308.1.4 is amended to read as follows:**

308.1.4 Open-flame cooking devices. Open-flame cooking devices, charcoal grills, and other similar devices used for cooking shall not be located or used on combustible balconies, decks, or within 10 feet (3,048 mm) of combustible construction.

Exceptions:

1. One- and two-family dwellings, except that LP-gas containers are limited to a water capacity not greater than 50 pounds (22.68 kg) [nominal 20 pound (9.08 kg) LP-gas capacity] with an aggregate LP-gas capacity not to exceed 100 lbs (5 containers).
2. Where buildings, balconies, and decks are protected by an approved automatic sprinkler system, except that LP-gas containers are limited to a water capacity not greater than 50 pounds (22.68 kg) [nominal 20 pound (9.08 kg) LP-gas capacity], with an aggregate LP-gas capacity not to exceed 40 lbs (2 containers).
3. LP-gas cooking devices having LP-gas container with a water capacity not greater than 2½ pounds [nominal 1 pound (0.454 kg) LP-gas capacity].

25. **Section of 308.1.4 is amended by adding Section 308.1.4.1 to read as follows:**

308.1.4.1 Burning of refuse prohibited. The burning of refuse in a barbeque grill or open-flame cooking device is not an approved method for refuse disposal, is declared a public nuisance, and is prohibited anywhere in the City of Allen. Refuse shall mean and include garbage, rubbish, and trade waste defined as follows:

Garbage. Garbage shall mean animal and vegetable matter such as that originating in houses, kitchens, restaurants, hotels, produce markets, food service or processing establishments, greenhouses, hospitals, clinics, or veterinary facilities.

Rubbish. Rubbish shall mean solids not considered to be highly flammable or explosive such as, but not limited to, rags, old clothes, leather, rubber, carpets, wood, excelsior, paper, ashes, tree branches, yard trimmings, furniture, metal food containers, glass, crockery, masonry, and other similar materials.

Trade Waste. Trade waste shall mean all solid or liquid material resulting from construction, building operations, or the prosecution or any business, trade or industry such as, but not limited to, plastic products, cinders and other forms of solid or liquid waste materials.

Materials Producing Dense Smoke Prohibited. The burning of rubber, asphaltic materials, combustible and flammable liquids, impregnated wood or similar materials which produce dense smoke are considered objectionable, a hazard, a public nuisance to the community, and are strictly prohibited.

26. **Section 308.1.6.2 is amended by amending paragraph number 3 under “Exceptions” to read as follows:**
3. Torches or flame-producing devices in accordance with Section 308.1.3.
27. **Section 308.1.6.3 is amended to read as follows:**
- 308.1.6.3 Sky Lanterns.** A person shall not release or cause to be released an unmanned free-floating devices containing an open flame or other heat source, such as but not limited to a sky lantern.
28. **Section 311.5 is amended to read as follows:**
- 311.5 Placards.** The Fire Code Official is authorized to require marking of any vacant or abandoned buildings or structures determined to be unsafe pursuant to Section 110 of this code relating to structural or interior hazards, as required by Section 311.5.1 through 311.5.5.
29. **Section 401.3 is amended by adding Section 401.3.4 to read as follows:**
- 401.3.4 Fire Alarms and Nuisance Alarms.** False alarms and nuisance alarms shall not be given, signaled, transmitted, caused, permitted to be given, signaled, or transmitted in any manner.
30. **Section 403.5 is amended to read as follows:**
- 403.5 Group E Occupancies.** An approved fire safety and evacuation plan in accordance with Section 404 shall be prepared and maintained for Group E occupancies and for buildings containing both a Group E occupancy and an atrium. A diagram depicting two evacuation routes shall be posted in a conspicuous location in each classroom. Group E occupancies shall also comply with Sections 403.5.1 through 403.5.3.
31. **Section 404.2.2 is amended by adding subparagraph 4.10 under paragraph to read as follows:**
- 4.10 Fire extinguishing system controls.
32. **Section 405.4 is amended to read as follows:**
- 405.4 Time.** The fire code official may require an evacuation drill at any time. Drills shall be held at unexpected times and under varying conditions to simulate the unusual conditions that occur in case of fire.
33. **Section 501.4 is amended to read as follows:**
- 501.4 Timing of installation.** When fire apparatus access roads or a water supply for fire protection is required to be installed for any structure or development, they shall be installed, tested, and approved prior to the time of which construction has progressed beyond completion of the foundation of any structure.
34. **Section 503.1.1 is amended to read as follows:**
- 503.1.1 Buildings and facilities.** Approved fire apparatus... *{intervening text unchanged}*...building or facility. Except for one- or two-family dwellings, the path of measurement shall be along a minimum of a ten feet (10') wide unobstructed pathway around the external walls of the structure.
- {“Exception” remains unchanged}

35 **Section 503.2.1 is amended to read as follows:**

503.2.1 Dimensions. Fire apparatus access roads shall have an unobstructed width of not less than 24 feet (7,315 mm), exclusive of shoulders, except for approved security gates in accordance with Section 503.6, and an unobstructed vertical clearance of not less than 14 feet (4,267 mm). Any such fire lane or fire apparatus access road shall either connect both ends to a dedicated street or be provided with a turnaround having a minimum outer radius of 50 feet. If two or more interconnecting fire lanes are provided, the interior radius for that connection shall be required to be in accordance with the following:

1. For 90 degree or greater turns only:
 - A 24 foot fire lane - 30 foot inside turning radius
 - B 30 foot fire lane-10 foot inside turning radius
2. For turns tighter than 90 degrees: American Association of State and Highway Transportation Officials (AASHTO) Geometric design of Highways and Streets shall be utilized.

Exception: Vertical clearance may be reduced; provided such reduction does not impair access by fire apparatus and approved signs are installed and maintained indicating the established vertical clearance when approved.

36. **Sections 503.2.2 is amended to read as follows:**

503.2.2 Authority. The Fire Code Official shall have the authority to require an increase in the minimum access widths and vertical clearances where they are inadequate for fire or rescue operations.

37. **Section 503.2.3 is amended to read as follows:**

503.2.3 Surface. Fire apparatus access roads shall be designed and maintained to support imposed loads of 95,000 Lbs. for fire apparatus and shall be surfaced so as to provide all-weather driving capabilities. All fire lanes shall be constructed to meet the City of Allen Engineering Standards.

38. **Section 503.2.5 is amended to read as follows:**

503.2.5 Dead ends. Dead end fire apparatus access roads are not permitted. An approved Fire Department vehicle access turn-around shall be required.

39. **Section 503.3 is amended to read as follows:**

503.3 Marking. Striping, signs, or other markings, when approved by the Fire Code Official, shall be provided for fire apparatus access roads to identify such roads or prohibit the obstruction thereof. Striping, signs and other markings shall be maintained in a clean and legible condition at all times and are replaced or repaired when necessary to provide adequate visibility.

1. **Striping.** Fire apparatus access roads shall be continuously marked by painted lines of red traffic paint six inches (6") in width to show the boundaries of the lane. The words "NO PARKING FIRE LANE" or "FIRE LANE NO PARKING" shall appear in four inch (4") white letters at 25 foot intervals on the red border markings along both sides of the fire lanes. Where a curb is available, the striping shall be on the vertical face of the curb.
2. **Signs.** Signs shall read "NO PARKING FIRE LANE" or "FIRE LANE NO PARKING" and shall be 12" wide and 18" high. Signs shall be painted on a white background with letters and borders in red, using not less than 2" lettering. Signs shall be permanently affixed to a stationary

post and the bottom of the sign shall be six feet, six inches (6'6") above finished grade. Signs shall be spaced not more than fifty feet (50') apart along both sides of the fire lane. Signs may be installed on permanent buildings or walls or as approved by the Fire Chief.

40. **Section 503.4 is amended to read as follows:**

503.4 Obstruction of fire apparatus access roads. Fire apparatus access roads shall not be obstructed in any manner, including the parking of vehicles, whether attended or unattended for any period of time. Persons in charge of a construction project, such as, but not limited to, a General Contractor, are responsible to ensure that fire apparatus access roads are kept clear of vehicles and other obstructions at all times and may be issued a citation for non-compliance under this section. The minimum widths and clearances established in Section 503.2.1 and any area marked as a fire lane as described in Section 503.3 shall be maintained at all times. The Fire Chief and Police Chief, and their designated representatives, are authorized to remove or cause to be removed any material, vehicle, or object obstructing a fire apparatus access road at the expense of the owner of such material, vehicle, or object.

503.4.1 Obstruction and Control. No owner or person in charge of any premises served by a fire lane or access easement shall abandon, restrict, or close any fire lane or easement without first securing from the City approval of an amended plat or other acceptable legal instrument showing the removal of the fire lane.

503.4.2 Speed control devices. Speed bumps or other similar obstacles designed to slow the speed of traffic and that have the effect of slowing or impeding the response of fire apparatus shall require a permit as required in Section 105.7 of this code prior to installation. Speed control devices shall be constructed out of concrete, by approved molded plastic, or a similar material.

41. **Section 503.6 is amended to read as follows:**

503.6.1 Security Gates. The installation of security gates or other devices intended to limit the access of vehicles or persons shall comply with the Fire Marshal's Office established written policy statement.

42. **Section 505.1 is amended to read as follows:**

505.1 Address identification. New and existing buildings shall be provided with approved address identification. The address identification shall be legible and placed in a position that is visible from the street or road fronting the property. Address identification characters shall contrast with their background. Address numbers shall be Arabic numbers or alphabetical letters. Numbers shall not be spelled out. Each character shall be not less than 6 inches (152.4 mm) high with a minimum stroke width of ½ inch (12.7 mm). Where required by the fire code official, address numbers shall be provided in additional approved locations to facilitate emergency response. Where access is by means of a private road, buildings do not immediately front a street, and/or the building cannot be viewed from the public way a monument, pole or other sign with approved 6 inch (152.4 mm) height building numerals or addresses and 4 inch (101.6 mm) height suite/apartment numerals of a color contrasting with the background of the building or other approved means shall be used to identify the structure. Numerals or addresses shall be posted on a minimum 20 inch (508 mm) by 30 inch (762 mm) background on border. Address identification shall be maintained.

505.1.1 Single family homes. R-3 Single Family occupancies shall have approved numerals of a minimum 4" high, 5/8" stroke and a color contrasting with the background clearly visible and legible from the street fronting the property and rear alleyway where such alleyway exists.

505.1.2 Multifamily Communities. Street Address shall be a minimum of 12" high with a 2" stroke. Individual building numbers shall be a minimum of 18" high with a 3" stroke. Buildings

over 100 feet in length require a minimum of two (2) numbers per building. Apartment spread numbers shall be a minimum of 7" high with a one inch stroke and corridor spread numbers shall be a minimum of 4" high with a 5/8" brush stroke. Individual apartment unit numbers shall be a minimum of 4" in height with a 5/8" stroke.

505.1.3 Large Office and Warehouse Buildings. Address must be visible from all access directions. Number shall be a minimum of 24" in height with a 4" stroke. Buildings over 500 feet long shall have two address locations if more than one access point is visible. Suite numbers shall be required for multi-tenant complexes and shall be located over the front door and on the rear door, 6" in height with a 1" brush stroke.

505.1.4 Shopping Centers, High Rise Buildings, and Other Applications. A minimum of 12" high numbers with a 2" brush stroke shall be visible from all access directions. Suite numbers are required over the door with 4" high numbers with a 5/8" brush stroke. Buildings beyond 100 feet from the street and 10,000 square feet shall install 18" numbers with a 3" stroke.

505.1.5 Marquee and Monument. Addresses installed on a marquee located next to the street will require numbers 12" high with a 2" brush stroke to be located a minimum of 3 feet above grade. Marquee and Monument signs must meet City of Allen Sign Ordinance Requirements.

43. **Section 505 is amended by adding a new Section 505.3 to read as follows:**

505.3 Directional/Equipment ID Signage. Directional and equipment identification signage may be required by the code official and shall meet the requirements as set forth in the Fire Marshal's Office written policy statement.

44. **Section 506.1 is amended by adding the following sentence at the end of the section:**

All new and existing occupancies, except single-family residences, shall provide (a) lock box(es) as specified in the Fire Marshal's Office written policy statement.

45. **Section 507.4 is amended to read as follows:**

507.4 Water supply test date and information. The water supply test used for hydraulic calculation of fire protection systems shall be conducted in accordance with NFPA 291 "Recommended Practice for Fire Flow Testing and Marking of Hydrants" and within one year of sprinkler plan submittal. The Fire Code Official shall be notified prior to the water supply test. Water supply tests shall be witnessed by the Fire Code Official, as required. The exact location of the static/residual hydrant and the flow hydrant shall be indicated on the design drawings. All fire protection plan submittals shall be accompanied by a hard copy of the waterflow test report, or as approved by the Fire Code Official. The report must indicate the dominant water tank level at the time of the test and the maximum and minimum operating levels of the tank, as well, or identify applicable water supply fluctuation. The licensed contractor must then design the fire protection system based on this fluctuation information, as per the applicable referenced NFPA standard. Reference Section 903.3.5 for additional design requirements.

46. **Section 507.5.1 is amended to read as follows:**

507.5.1 Where required. As properties develop, fire hydrants shall be located at all intersecting streets and at the maximum spacing indicated in Table 507.5.1. Distances between hydrants shall be measured along the route that fire hose is laid by a fire vehicle from hydrant to hydrant.

**TABLE 507.5.1
MAXIMUM DISTANCE BETWEEN HYDRANTS**

OCCUPANCY	SPRINKLERED	NOT SPRINKLERED
Residential (1 & 2 Family)	600 feet	500 feet
Residential (Multi-Family)	400 feet	300 feet
All Other	500 feet	300 feet

There shall be a minimum of two (2) fire hydrants serving each property within the prescribed distance listed in Table 507.5.1.

Protected Properties. Fire Hydrants shall be installed along fire lanes with spacing as required for street installations specified in 507.5.1. In addition, hydrants required to provide supplemental water supply for automatic fire protection systems shall be within 100 feet of the Fire Department connection (FDC) for such systems.

47. **Section 507.5.4 is amended to read as follows:**

507.5.4 Obstruction. Unobstructed access to fire hydrants shall be maintained at all times. Posts, fences, vehicles, growth, trash, storage and other materials or objects shall not be placed or kept near fire hydrants, Fire Department inlet connections or fire protection system control valves in a manner that would prevent such equipment or fire hydrants from being immediately discernible. The Fire Department shall not be deterred or hindered from gaining immediate access to fire protection equipment or fire hydrants.

48. **Section 507.5 is amended by adding Sections 507.5.7 through 507.5.16 to read as follows:**

507.5.7 Fire Hydrant Type. All hydrants shall be of the three-way type with National Standard threads, breakaway construction, minimum 5¼" valve opening and shall comply with the latest AWWA specification C-502. The hydrant shall have a 4½" large connection with two 2½" side connections and shall be placed on water mains of no less than six inches (6") in size. Fire hydrants shall be Mueller "Centurion" or approved equal.

507.5.8 Valves. Valves shall be placed on all fire hydrants leads.

507.5.9 Breakaway point. Fire hydrants shall be installed so that the breakaway point is no less than three (3) inches, and no greater than five (5) inches above the grade surface.

507.5.10 Curb Line. Fire hydrants shall be located a minimum of two (2) feet and a maximum of six (6) feet behind the curb line. No fire hydrant shall be placed in a cul-de-sac or the turning radius of fire lanes.

507.5.11 Positioning. All fire hydrants shall be installed so that the 4½" connection will face the fire lane or street.

507.5.12 Limiting Access Obstruction. Fire hydrants, when placed at intersections or access drives to parking lots, shall be placed so that the minimum obstruction of the intersection or access drive will occur when the hydrant is in use.

507.5.13 Private Property. Fire hydrants located on private property shall be accessible to the Fire Department at all times.

All fire hydrants placed on private property shall be adequately protected by either curb stops, concrete posts or other approved methods. Such stops shall be the responsibility of the landowner on which the fire hydrant is installed.

507.5.14 Location to Building. Fire hydrants shall not be located closer than 50' to a building or height of building + 10'.

507.5.15 Identification. An approved blue, two-sided reflector shall be utilized to identify each hydrant location. The reflector shall be affixed to the center line of each roadway or fire access lane opposite fire hydrants.

507.5.16 Color. Fire hydrant caps and bonnet shall be painted according to the water main size to which it is attached (see Table 507.5.16). The remainder of the hydrant above ground shall be painted silver.

Table 507.5.16

MAIN SIZE	COLOR
6"	Silver
8"	Blue
10" or greater	Yellow

49. **Section 509.1 is amended by adding Section 509.1.1 to read as follows:**

509.1.1 Sign Requirements. Unless more stringent requirements apply, lettering for signs required by this Section shall have a minimum height of two (2) inches when located inside a building and four (4) inches when located outside, or as approved by the Fire Code Official. The letters shall be of a color that contrasts with the background.

50. **Section 603.3.1 is amended to read as follows:**

603.3.1 Fuel oil storage in outside, above-ground tanks. Where connected to a fuel-oil piping system, the maximum amount of fuel oil storage allowed outside above ground without additional protection shall be 660 gallons (2498 L). The storage of fuel oil above ground in quantities exceeding 660 gallons (2498 L) shall comply with NFPA 31 and Chapter 57.

51. Section 603.3.2 is amended to read as follows:

603.3.2 Fuel oil storage inside buildings. Fuel oil storage inside buildings shall comply with Sections 603.3.2.1 through 603.3.2.5 and Chapter 57.

52. **Section 603.3.2.1 is amended to read as follows:**

603.3.2.1 Quantity limits. One or more fuel oil storage tanks containing Class II or III combustible liquid shall be permitted in a building. The aggregate capacity of all tanks shall not exceed the following:

1. 660 gallons (2498 L) in unsprinklered buildings, where stored in a tank complying with UL 80, UL142 or UL2085 for Class III liquids, and also listed as a double-wall/secondary containment tank for Class II liquids.

2. 1,320 gallons (4996 L) in buildings equipped with an automatic sprinkler system in accordance with Section 903.3.1.1, where stored in a tank complying with UL 142 or UL 2085 as a double-wall secondary containment tank.
3. 3,000 gallons (11 356 L) where stored in protected above-ground tanks complying with UL 2085 and Section 5704.2.9.7 and the room is protected by an automatic sprinkler system in accordance with Section 903.3.1.1

53. **Section 807.5.2.2 is amended to read as follows:**

807.5.2.2 Artwork in Corridors. Artwork and teaching materials shall be limited on the walls of corridors to not more than 20 percent of the wall area. Such materials shall not be continuous from floor to ceiling or wall to wall. Curtains, draperies, wall hangings, and other decorative material suspended from the walls or ceilings shall meet the flame propagation performance criteria of NFPA 701 in accordance with Section 807 or be noncombustible.

Exception: Corridors protected by an approved automatic sprinkler system installed in accordance with Section 903.3.1.1 shall be limited to 50 percent of the wall area.

54. **Section 807.5.2.3 is amended to read as follows:**

807.5.2.3 Artwork in Classrooms. Artwork and teaching materials shall be limited on walls of classrooms to not more than 50 percent of the specific wall area to which they are attached. Curtains, draperies, wall hangings and other decorative material suspended from the walls or ceilings shall meet the flame propagation performance criteria of NFPA 701 in accordance with Section 807 or be noncombustible.

55. **Section 901.6.1 is amended by adding Section 901.6.1.1 to read as follows:**

901.6.1.1 Standpipe Testing. Building owners/managers must maintain and test standpipe systems as per NFPA 25 requirements. The following additional requirements shall be applied to the testing that is required every 5 years:

1. The piping between the Fire Department Connection (FDC) and the standpipe shall be hydrostatically tested for all FDC's on any type of standpipe system. Hydrostatic testing shall also be conducted in accordance with NFPA 25 requirements for the different types of standpipe systems.
2. For any manual (dry or wet) standpipe system not having an automatic water supply capable of flowing water through the standpipe, the tester shall connect hose from a fire hydrant or portable pumping system (as approved by the Fire Code Official) to each FDC, and flow water through the standpipe system to the roof outlet to verify that each inlet connection functions properly. Confirm that there are no open hose valves prior to introducing water into a dry standpipe. There is no pressure criteria required at the outlet. Verify that check valves function properly and that there are no closed control valves on the system.
3. Any pressure relief, reducing, or control valves shall be tested in accordance with the requirements of NFPA 25. All hose valves shall be exercised.
4. If the FDC is not already provided with approved caps, the contractor shall install such caps for all FDC's as required by the Fire Code Official.
5. Upon successful completion of standpipe test, place a blue tag (as per "Texas Administrative Code, Fire Sprinkler Rules for Inspection, Test and Maintenance Service (ITM) Tag) at the

bottom of each standpipe riser in the building. The tag shall be check-marked as "Fifth Year" for Type of ITM, and the note on the back of the tag shall read "5 Year Standpipe Test" at a minimum.

6. The procedures required by the Texas Administrative Code Fire Sprinkler Rules with regard to Yellow Tags and Red Tags or any deficiencies noted during the testing, including the required notification of the local Authority Having Jurisdiction (Fire Code Official) shall be followed.
 7. Additionally, records of the testing shall be maintained by the owner and contractor, if applicable, as required by the State Rules mentioned above and NFPA 25.
 8. Standpipe system tests where water will be flowed external to the building shall not be conducted during freezing conditions or during the day prior to expected night time freezing conditions.
 9. Contact the Fire Code Official for requests to remove existing fire hose from Class II and III standpipe systems where employees are not trained in the utilization of this firefighting equipment. All standpipe hose valves must remain in place and be provided with an approved cap and chain when approval is given to remove hose by the Fire Code Official.
56. **Section 906.1 is amended by adding Section 901.6.3 to read as follows:**
- 901.6.3 False Alarms and Nuisance Alarms.** False alarms and nuisance alarms shall not be given, signaled or transmitted or caused or permitted to be given, signaled or transmitted in any manner.
57. **Section 901.7 is amended to read as follows:**
- 901.7 Systems Out of Service.** Where a required fire protection system is out of service or in the event of an excessive number of activations, the fire department and the fire code official shall be notified immediately and, where required by the fire code official, the building shall either be evacuated or an approved fire watch shall be provided for all occupants left unprotected by the shut down until the fire protection system has been returned to service. ... *{remaining text unchanged}*
58. **Section 903.1.1 is amended to read as follows:**
- 903.1.1 Alternative protection.** Alternative automatic fire-extinguishing systems complying with Section 904 shall be permitted in addition to automatic sprinkler protection where recognized by the applicable standard, or as provided by the Fire Code Official.
59. **Section 903.1 is amended by adding Section 903.1.2 to read as follows:**
- 903.1.2 Residential Systems.** Unless specifically allowed by this code or the International Building Code, residential sprinkler systems installed in accordance with NFPA 13D or NFPA 13R shall not be recognized for the purpose of exceptions or reductions, commonly referred to as "trade-offs," permitted by other requirements of this code. In addition, residential sprinkler systems installed in accordance with NFPA 13R must include attics, breezeways, and patios. Garage areas must also be covered in residential sprinkler systems installed in accordance with NFPA 13D and NFPA 13R.

Exception: Group R-3 attached garages need not be sprinklered throughout if a dry sprinkler is installed within 5 feet (1,524 mm) of the door opening between the garage and attached residence.

Residential fire sprinkler risers shall be located on a heated wall in the garage.

Exception: Other riser location as approved by the Allen Fire Department Prevention Division.

60. **Section 903.2 is amended to read as follows:**

903.2 Where required. Approved automatic sprinkler systems in new buildings and structures shall be provided in the locations described in Sections 903.2.1 through 903.2.12. Automatic Sprinklers shall not be installed in elevator machine rooms, elevator machine spaces, and elevator hoistways. Storage shall not be allowed within the elevator machine room. Signage shall be provided at the entry doors to the elevator machine room indicating "ELEVATOR MACHINERY - NO STORAGE ALLOWED."

61. **Section 903.2 is further amended by deleting the paragraph titled "Exception."**

62. **Section 903.2.9 is amended by adding Section 903.2.9.3 to read as follows:**

903.2.9.3 Self-service storage facility. An automatic sprinkler system shall be installed throughout all self-service storage facilities. A screen shall be installed at eighteen (18") inches below the level of the sprinkler heads to restrict storage above that level. This screen shall be a mesh of not less than one (1) inch not greater than six (6") inches in size. This screen and its supports shall be installed such that all elements are at least eighteen (18") inches below any sprinkler head.

63. **Section 903.2.11.3 is amended to read as follows:**

903.2.11.3 Buildings 35 feet or more in height. An automatic sprinkler system shall be installed throughout buildings with a floor level, other than penthouses in compliance with Section 1510 of the International Building Code, located 35 feet (10,668 mm) or more above the lowest level of Fire Department vehicle access.

Exception: Open parking structures in compliance with Section 406.5 of the International Building Code.

64. **Section 903.2.11 is amended by adding Sections 903.2.11.7, 903.2.11.8, and 903.2.11.9 to read as follows:**

903.2.11.7 High-Piled Combustible Storage. For any building with a clear height exceeding 12 feet (4,572 mm), see Chapter 32 to determine if those provisions apply.

903.2.11.8 Spray Booths and Rooms. New and existing spray booths and spraying rooms shall be protected by an approved automatic fire-extinguishing system.

903.2.11.9 Buildings Over 6,000 sq. ft. An automatic sprinkler system shall be installed throughout all buildings with a building area over 6,000 sq. ft. For the purpose of this provision, fire walls shall not define separate buildings. For this Section only, area measurement shall be based on outside dimensions of exterior walls, exclusive of vent shafts and courts, without deduction for corridors, stairways, closets, the thickness of interior walls, columns or other features. The floor area of a building, or portion thereof, not provided with surrounding exterior walls shall be the usable area under the horizontal projection of the roof or floor above. For upper level attic type rooms areas where the ceiling height is less than five feet (5'0") shall not be considered. Unfinished space framed to permit future expansion of floor area shall be considered as part of the area. Joists designed to support floor loads shall be assumed to be for future area.

Exception: Open parking garages in compliance with Section 406.5 of the International Building Code.

903.2.11.9.1 Modifications, repairs, and additions to existing buildings. An automatic sprinkler system shall be installed throughout in accordance with NFPA 13, 13D, or 13R as applicable and this code in all existing buildings when:

1. Enlarged to be 6,000 square feet or greater.
2. Greater than 6,000 square feet and the square footage increased.
3. The cumulative remodel of any building, over any period of time, from the original adoption of this ordinance (Ord. No. 3013-5-11, § 1, 5-24-2011) that is equal to or is greater than 6,000 square feet.
4. Fifty (50) percent or more of the roof assembly is replaced, or repaired, due to fire damage or structural failure, or when the removal of existing fire rated assemblies result in an increase of the original basic allowable area.
5. Required to be protected in accordance with this Code or other provisions of Article III of the ALDC.

65. **Section 903.3.1.1.1 is amended to read as follows:**

903.3.1.1.1 Exempt locations. When approved by the Fire Code Official, automatic sprinklers shall not be required in the following rooms or areas where such . . . {text unchanged} . . . because it is damp, of fire-resistance-rated construction, or contains electrical equipment.

1. Any room where the application of water, or flame and water, constitutes a serious life or fire hazard.
2. Any room or space where sprinklers are considered undesirable because of the nature of the contents, when approved by the Code Official.
3. Generator and transformer rooms, under the direct control of a public utility, separated from the remainder of the building by walls and floor/ceiling or roof/ceiling assemblies having a fire-resistance rating of not less than 2 hours.
4. Elevator machine rooms, machinery spaces, and hoistways, other than pits where such sprinklers would not necessitate shunt trip requirements under any circumstances.

66. **Section 903.3.1.2.3 is amended to read as follows:**

903.3.1.2.3 Attics and Attached Garages. Sprinkler protection is required in attached garages, and in the following attic spaces:

1. Attics that are used or intended for living purposes or storage shall be in attic spaces of such buildings two or more stories in height, in accordance with NFPA 13 and or NFPA 13R requirements, and attached garages.
2. Where fuel-fired equipment is installed in an unsprinklered attic, not fewer than one quick response intermediate temperature sprinkler shall be installed above the equipment.
3. Attic spaces of buildings that are two or more stories in height above grade plane or above the lowest level of fire department vehicle access.

4. Group R-4, Condition 2 occupancy attics not required by Item 1 or 3 to have sprinklers shall comply with one of the following:
 - 4.1 Provide automatic sprinkler system protection.
 - 4.2 Provide a heat detection system throughout the attic that is arranged to activate the building fire alarm system.
 - 4.3 Construct the attic using noncombustible materials.
 - 4.4 Construct the attic using fire-retardant-treated wood complying with Section 2303.2 of the International Building Code.
 - 4.5 Fill the attic with non-combustible insulation.

67. **Section 903.3.1.3 is amended to read as follows:**

903.3.1.3 NFPA 13D Sprinkler Systems. Automatic sprinkler systems installed in one- and two-family dwellings; Group R-3; Group R-4 Condition 1 and townhouses shall be permitted to be installed throughout in accordance with NFPA 13D or in accordance with state law.

68. **Section 903.3.1 is amended by adding Section 903.3.1.4 to read as follows:**

903.3.1.4 Freeze protection. Freeze protection systems for automatic fire sprinkler systems shall be in accordance with the requirements of the applicable referenced NFPA standard and this section.

903.3.1.4.1 Attics. Only dry-pipe, preaction, or listed antifreeze automatic fire sprinkler systems shall be allowed to protect attic spaces.

Exception: Wet-pipe fire sprinkler systems shall be allowed to protect non-ventilated attic spaces where:

1. The attic sprinklers are supplied by a separate floor control valve assembly to allow ease of draining the attic system without impairing sprinklers throughout the rest of the building, and
2. Adequate heat shall be provided for freeze protection as per the applicable referenced NFPA standard, and
3. The attic space is a part of the building's thermal, or heat, envelope, such that insulation is provided at the roof deck, rather than at the ceiling level.

903.3.1.4.2 Heat trace/insulation. Heat trace/insulation shall only be allowed where approved by the fire code official for small sections of large diameter water-filled pipe.

69. **Section 903.3.5 is amended by adding the following sentence at the end of the section:**

Water supply as required for such systems shall be provided in conformance with the supply requirements of the respective standards; however, every fire protection system shall be designed with a 10 psi safety factor. Reference Section 507.4 for additional design requirements.

70. **Section 903.3.7.1 is amended to add the following:**

903.3.7.1 Missing or damaged FDC caps. Missing or damaged FDC caps shall be replaced with locking "Knox" FDC caps. All new FDCs and standpipe hose valve connections shall have Knox caps or plugs installed.

71. **Section 903.4 is amended by adding the following paragraph after the paragraph titled "Exceptions":**

Sprinkler and standpipe system water-flow detectors shall be provided for each floor tap to the sprinkler system and shall cause an alarm upon detection of water flow for more than 45 seconds. All control valves in the sprinkler and standpipe systems except for Fire Department hose connection valves shall be electrically supervised to initiate a supervisory signal at the central station upon tampering.

72. **Section 903.4 is amended by adding Sections 903.4.4 and 903.4.5 to read as follows:**

903.4.4 Individual zone controls. Individual zone control valves shall be installed as follows:

1. Multi-story buildings shall be zoned by floor and have separate control valves installed that will allow each floor to be independently shut-off without having an effect on the operation of the sprinkler system on other floors.
2. Multi-story multi-family residential buildings that are separated by a breezeway or fire rated assembly can be zoned by building section if approved in advance by Allen Fire Rescue. The required sectional control valves shall be located in the main sprinkler control valve room or as directed by the Chief or his designee.
3. Hazardous areas such as spray booths, flammable liquid storage rooms, etc. shall be separate zones and have separate control valves installed that will allow the sprinkler system in these areas to be independently shut-off without having an effect on the operation of the system in other areas. The required zone control valves shall be located in an accessible area outside the spray booth or room or in the main sprinkler control valve room.
4. Special systems such as pre-action systems shall be separate zones and have separate control valves installed that will allow the sprinkler system in these areas to be independently shut-off without having an effect on the operation of the system in other areas.
5. Computer rooms shall be separate zones and have separate control valves installed that will allow the sprinkler system in these areas to be independently shut-off without having an effect on the operation of the system in other areas.
6. Where sprinklers are installed in racks, separate indicating control valves and drains shall be provided and arranged so that ceiling and in-rack sprinklers can be controlled independently.
7. Subfloor areas shall have separate control valves installed that will allow the subfloor area to be independently shutoff without having an effect on the operation of the sprinkler system in other areas. The required zone control valves shall be located in an accessible area outside the subfloor area.
8. Where the zoning of the sprinkler system and installation of separate control valves will increase the level of fire protection for the building, and the life safety of the occupants and firefighters as determined by the Fire Marshal (AHJ).

903.4.5 Monitoring and Supervising. All valves on connections to water supplies, sectional control and isolation valves, and other valves in supply pipes to sprinklers and other fixed water-based fire suppression systems shall be supervised and monitored at all times. Graphic maps shall be posted in

the sprinkler riser room depicting sprinkler zones. Proper tagging and/or signage complying with Fire Department specifications shall identify all valves as to their function and identify their location

73. **Section 903.4.2 is amended by adding the following sentence at the end of the section:**

The alarm device required on the exterior of the building shall be a weatherproof horn/strobe notification appliance with a minimum 75 candela strobe rating, installed as close as practicable to the fire department connection.

74. **Section 903.6 is amended by adding Section 903.6.1 to read as follows:**

903.6.1 Spray booths and rooms. New and existing spray booths and spray rooms shall be protected by an approved automatic fire-extinguishing system in accordance with Section 2404.

75. **Section 905.2 is amended to read as follows:**

905.2 Installation standard. Standpipe systems shall be installed in accordance with this Section and NFPA 14. Manual dry standpipe systems shall be supervised with a minimum of 10 psig and a maximum of 40 psig air pressure with a high/low alarm.

76. **Section 905.3 is amended by adding Section 905.3.9 to read as follows:**

905.3.9 Building area. In buildings exceeding 10,000 square feet in area per story and where any portion of the building's interior area is more than 200 feet (60960 mm) of travel, vertically and horizontally, from the nearest point of fire department vehicle access, Class I automatic wet or manual wet standpipes shall be provided.

Exceptions:

1. Automatic dry and semi-automatic dry standpipes are allowed as provided for in NFPA 14.
2. R-2 occupancies of four stories or less in height having no interior corridors.

77. **Section 905.4 is amended by amending numbered paragraphs 1, 3, and 5 to read as follows:**

1. In every required exit stairway, a hose connection shall be provided for each story above and below grade plane. Hose connections shall be located at an intermediate landing between stories, unless otherwise approved by the fire code official.

3. In every exit passageway, at the entrance from the exit passageway to other areas of a building.

Exception: Where floor areas adjacent to an exit passageway are reachable from an exit stairway hose connection by a ... {remainder of Exception unchanged}

5. Where the roof has a slope less than four units vertical in 12 units horizontal (33.3-percent slope), each standpipe shall be provided with a two-way hose connection located to serve the roof or at the highest landing of an exit stairway with stair access to the roof provided in accordance with Section 1011.12.

78. **Section 905.4 is amended by adding a new numbered paragraph 7 to read as follows:**

7. When required by this Chapter, standpipe connections shall be placed adjacent to all required exits to the structure and at two hundred feet (200') intervals along major corridors thereafter, or as otherwise approved by the fire code official.

79. **Section 905.9 is amended by adding the following paragraph after the “Exceptions”:**

Sprinkler and standpipe system water-flow detectors shall be provided for each floor tap to the sprinkler system and shall cause an alarm upon detection of water flow for more than 45 seconds. All control valves in the sprinkler and standpipe systems, except for Fire Department hose connection valves, shall be electrically supervised to initiate a supervisory signal at the central station upon tampering.

80. **Section 907.1 is amended by adding Section 907.1.4 to read as follows:**

907.1.4 Design Standards. All alarm systems, new or replacements, shall be addressable. Alarm systems serving more than 20 smoke detectors shall have analog initiating devices.

81. **Section 907.2.1 is amended to read as follows:**

907.2.1 Group A. A manual fire alarm system that activates the occupant notification system in accordance with new Section 907.5 shall be installed in Group A occupancies having an occupant load of 300 or more persons or more than 100 persons above or below the lowest level of exit discharge. Group A occupancies not separated from one another in accordance with Section 707.3. 10 of the International Building Code shall be considered as a single occupancy for the purposes of applying this section. Portions of Group E occupancies occupied for assembly purposes shall be provided with a fire alarm system as required for the Group E occupancy.

Exception: {No change.}

Activation of fire alarm notification appliances shall:

1. Cause illumination of the means of egress with light of not less than 1 foot-candle (11 lux) at the walking surface level, and
2. Stop any conflicting or confusing sounds and visual distractions.

82. **Section 907.2.3 is amended by amending the first paragraph and adding paragraph 1.1 under paragraph 1 of “Exceptions” to read as follows:**

907.2.3 Group E. A manual fire alarm system that initiates the occupant notification signal utilizing an emergency voice/alarm communication system meeting the requirements of Section 907.5.2.2 and installed in accordance with Section 907.6 shall be installed in Group E educational occupancies. When automatic sprinkler systems or smoke detectors are installed, such systems or detectors shall be connected to the building fire alarm system. An approved smoke detection system shall be installed in Group E day care occupancies. Unless separated by a minimum of 100' open space, all buildings, whether portable buildings or the main building, will be considered one building for alarm occupant load consideration and interconnection of alarm systems.

Exceptions:

1. {No change.}
- 1.1. Residential In-Home day care with not more than 12 children may use interconnected single station detectors in all habitable rooms. (For care of more than five children 2 1/2 or less years of age, see Section 907.2.6.)

83. Section 907.2.12 is amended by amending Exception 3 to read as follows:

3. Open air portions of buildings with an occupancy in Group A-5 in accordance with Section 303.1 of the International Building Code, when used for open air seating; however, this Exception does not apply to accessory uses including but not limited to sky boxes, restaurants and similarly enclosed areas.
84. **Section 907.4.2 is amended by adding Section 907.4.2.7 to read as follows:**
- 907.4.2.7 Type.** Manual alarm initiating devices shall be an approved double action type.
85. **Section 907.6.1 is amended by adding Section 907.6.1.1 to read as follows:**
- 907.6.1.1 Wiring Installation.** All fire alarm systems shall be installed in such a manner that a failure of any single initiating device or single open in an initiating circuit conductor will not interfere with the normal operation of other such devices. All signaling line circuits (SLC) shall be installed in such a way that a single open will not interfere with the operation of any addressable devices (Class A). Outgoing and return SLC conductors shall be installed in accordance with NFPA 72 requirements for Class A circuits and shall have a minimum of four feet separation horizontal and one foot vertical between supply and return circuit conductors. The initiating device circuit (IDC) from a signaling line circuit interface device may be wired Class B, provided the distance from the interface device to the initiating device is ten feet or less.
86. **Section 907.6.3 is amended by deleting all four Exceptions.**
87. **Section 907.6.6 is amended by adding the following sentence to end of the paragraph:**
- See 907.6.3 for the required information transmitted to the supervising station.*
88. **Section 907.6.6 is amended by adding Section 907.6.6.3 to read as follows:**
- 906.6.6.3 Communication requirements.** All alarm systems, new or replacements, shall transmit alarm, supervisory and trouble signals descriptively to the approved central station, remote supervisory station or proprietary supervising station as defined in NFPA 72, with the correct device designation and location of addressable device identification. Alarms shall not be permitted to be transmitted as a General Alarm or Zone condition.
89. **Section 907 is amended by adding Section 907.11 to read as follows:**
- 907.11 Password Protection Prohibited.** No fire alarm system shall be protected by a password or pin number that would hinder immediate silencing capabilities by the Fire Department.
90. **Section 909 is amended by adding Section 909.22 to read as follows:**
- 909.22 Stairway or Ramp Pressurization Alternative.** Where the building is equipped throughout with an automatic sprinkler system in accordance with Section 903.3.1.1 and the stair pressurization alternative is chosen for compliance with Building Code requirements for a smokeproof enclosure, interior exit stairways or ramps shall be pressurized to a minimum of 0.10 inches of water (25 Pa) and a maximum of 0.35 inches of water (87 Pa) in the shaft relative to the building measured with all interior exit stairway and ramp doors closed under maximum anticipated conditions of stack effect and wind effect. Such systems shall comply with Section 909, including the installation of a separate fire-fighter's smoke control panel as per Section 909.16, and a Smoke Control Permit shall be required from the fire department as per Section 105.7.

[F] **909.22.1 Ventilating equipment.** The activation of ventilating equipment for the stair or ramp pressurization system shall be by smoke detectors installed at each floor level at an approved

location at the entrance to the smokeproof enclosure. When the closing device for the stairway or ramp shaft and vestibule doors is activated by smoke detection or power failure, the mechanical equipment shall activate and operate at the required performance levels. Smoke detectors shall be installed in accordance with Section 907.3.

909.22.1.1 Ventilation Systems. Smokeproof enclosure ventilation systems shall be independent of other building ventilation systems. The equipment, control wiring, power wiring and ductwork shall comply with one of the following:

1. Equipment, control wiring, power wiring and ductwork shall be located exterior to the building and directly connected to the smokeproof enclosure or connected to the smokeproof enclosure by ductwork enclosed by not less than 2-hour fire barriers constructed in accordance with Section 707 of the Building Code or horizontal assemblies constructed in accordance with Section 711 of the Building Code, or both.
2. Equipment, control wiring, power wiring and ductwork shall be located within the smokeproof enclosure with intake or exhaust directly from and to the outside or through ductwork enclosed by not less than 2-hour barriers constructed in accordance with Section 707 of the Building Code or horizontal assemblies constructed in accordance with Section 711 of the Building Code, or both.
3. Equipment, control wiring, power wiring and ductwork shall be located within the building if separated from the remainder of the building, including other mechanical equipment, by not less than 2-hour fire barriers constructed in accordance with Section 707 of the Building Code or horizontal assemblies constructed in accordance with Section 711 of the Building Code, or both.

Exceptions:

1. Control wiring and power wiring utilizing a 2-hour rated cable or cable system.
2. Where encased with not less than 2 inches (51 mm) of concrete.
3. Control wiring and power wiring protected by a listed electrical circuit protective systems with a fire-resistance rating of not less than 2 hours.

909.22.1.2 Standby Power. Mechanical vestibule and stairway and ramp shaft ventilation systems and automatic fire detection systems shall be provided with standby power in accordance with Section 2702 of the Building Code.

909.22.1.3 Acceptance and Testing. Before the mechanical equipment is approved, the system shall be tested in the presence of the fire code official to confirm that the system is operating in compliance with these requirements.⁸⁹ Section 910.2 of the International Fire Code, 2018 edition, Exception 2 and 3 are amended to read as follows:

91. **Section 910.2 is amended by amending paragraphs 2 and 3 under “Exceptions” to read as follows:**

[F] 2. Only manual smoke and heat removal shall be required in areas of buildings equipped with early suppression fast-response (ESFR) sprinklers. Automatic smoke and heat removal is prohibited.

3. Only manual smoke and heat removal shall not be required in areas of buildings equipped with control mode special application sprinklers with a response time index of $50(m^*S)^{1/2}$ or less that are listed to control a fire in stored commodities with 12 or fewer sprinklers. Automatic smoke and heat removal is prohibited.

92. **Section 910.2.3 is amended by adding Section 910.2.3 to read as follows:**

910.2.3 Group H. Buildings and portions thereof used as a Group H occupancy as follows:

1. In occupancies classified as Group H-2 or H-3, any of which are more than 15,000 square feet (1,394 m²) in single floor area.

Exception: Buildings of noncombustible construction containing only noncombustible materials.

2. In areas of buildings in Group H used for storing Class 2, 3 and 4 liquid and solid oxidizers, Class 1 and unclassified detonable organic peroxides, Class 3 and 4 unstable (reactive) materials, or Class 2 or 3 water-reactive materials as required for a high-hazard commodity classification.

Exception: Buildings of noncombustible construction containing only noncombustible materials.

93. **Section 910.3 is amended by adding Section 910.3.4 to read as follows:**

910.3.4 Vent Operation. Smoke and heat vents shall be capable of being operated by approved automatic and manual means. Automatic operation of smoke and heat vents shall conform to the provisions of Sections 910.3.2.1 through 910.3.2.3.

[F] **910.3.4.1 Sprinklered buildings.** Where installed in buildings equipped with an approved automatic sprinkler system, smoke and heat vents shall be designed to operate automatically.

The automatic operating mechanism of the smoke and heat vents shall operate at a temperature rating at least 100 degrees F (approximately 38 degrees Celsius) greater than the temperature rating of the sprinklers installed.

Exception: Manual only systems per Section 910.2.

910.3.4.2 Nonsprinklered Buildings. Where installed in buildings not equipped with an approved automatic sprinkler system, smoke and heat vents shall operate automatically by actuation of a heat-responsive device rated at between 100°F (56°C) and 220°F (122°C) above ambient.

Exception: Listed gravity-operated drop out vents.

94. Section 910.4.3.1 of the International Fire Code **Section 910.4.3.1 is amended to read as follows:**

910.4.3.1 Makeup Air. Makeup air openings shall be provided within 6 feet (1829 mm) of the floor level. Operation of makeup air openings shall be automatic. The minimum gross area of makeup air inlets shall be 8 square feet per 1,000 cubic feet per minute (0.74 m² per 0.4719 m³/s) of smoke exhaust.

95. **Section 912.2 is amended by adding Section 912.2.3 to read as follows:**

912.2.3 Hydrant distance. An approved fire hydrant shall be located within 100 feet of the Fire Department connection as the fire hose lays along an unobstructed path

96. **Section 913.2.1 is amended by adding the following sentence and Exception to read as follows:**

...When located on the ground level at an exterior wall, the fire pump room shall be provided with an exterior Fire Department access door that is not less than 3 ft. in width and 6 ft. - 8 in. in height, regardless of any interior doors that are provided. A key box shall be provided at this door, as required by Section 506.1.

Exception: When it is necessary to locate the fire pump room on other levels or not at an exterior wall, the corridor leading to the fire pump room access from the exterior of the building shall be provided with equivalent fire resistance as that required for the pump room, or as approved by the Fire Code Official. Access keys shall be provided in the key box as required by Section 506.1.

97. **Section 913.4 is amended by adding the following sentence at the end of the section:**

The fire-pump system shall also be supervised for "loss of power," "phase reversal," and "pump running" conditions by supervisory signal on district circuits.

98. **Section 914.3.1.2 is amended to read as follows:**

914.3.1.2 Water Supply to required Fire Pumps. In buildings that are more than 120 feet (128 m) in building height, required fire pumps shall be supplied by connections to no fewer than two water mains located in different streets. Separate supply piping shall be provided between each connection to the water main and the pumps. Each connection and the supply piping between the connection and the pumps shall be sized to supply the flow and pressure required for the pumps to operate.

Exception: {No change to exception.}

99. **Section 1006.2.2 is amended by adding Section 1006.2.2.6 to read as follows:**

1006.2.2.6 Electrical Rooms. For electrical rooms, special exiting requirements may apply. Reference the Electrical Code as adopted.

100. **Section 1009.8 is amended by adding Exception 7 to read as follows:**

7. Buildings regulated under State Law and built in accordance with State registered plans, including any variances or waivers granted by the State, shall be deemed to be in compliance with the requirements of Section 1009 and chapter 11.

101. **Section 1010.1.9.5 is amended by amending Exceptions 3 and 4 to read as follows:**

3. Where a pair of doors serves an occupant load of less than 50 persons in a Group B, F, M or S occupancy. *{Remainder unchanged}*

4. Where a pair of doors serves a Group A, B, F, M or S occupancy *{Remainder unchanged}*

102. **Section 1015.8 is amended by amending paragraph 1 to read as follows:**

1. Operable windows where the top of the sill of the opening is located more than 55 (16 764 mm) above the finished grade or other surface below and that are provided with window fall prevention devices that comply with ASTM F 2006.

103. **Section 1020.1 is amended by adding paragraph 6 under "Exceptions" to read as follows:**

6. In Group B occupancies, corridor walls and ceilings need not be of fire-resistive construction within a single tenant when the space is equipped with an approved automatic fire alarm system with corridor smoke detection. The actuation of any detector shall activate alarms audible in

all areas served by the corridor. The smoke-detection system shall be connected to the building's fire alarm system where such a system is provided.

104. **Section 1029.1.1.1 is deleted.**

105. **Section 1031.2 is amended to read as follows:**

1030.2 Reliability. Required exit accesses, exits or exit discharges shall be continuously maintained free from obstructions or impediments to full instant use in the case of fire or other emergency. An exit or exit passageway shall not be used for any purpose that interferes with a means of egress. Security devices affecting means of egress shall be subject to approval of the Fire Code Official.

106. **Section 1103.3 is amended by adding the following sentence to end of paragraph:**

Provide emergency signage as required by Section 606.3.

107. **Section 1103.5.1 is amended by adding the following sentence to end of paragraph:**

Fire sprinkler system installation shall be completed with 24 months from date of notification by the fire code official.

108. **Section 1103.5 is amended by adding Section 1103.5.5 to read as follows:**

1103.5.5 Spray Booths and Rooms. Existing spray booths and spray rooms shall be protected by an approved automatic fire-extinguishing system in accordance with Section 2404.

109. **Section 1103.7 is amended by adding Sections 1103.7.7 and 1103.7.7.1 to read as follows:**

1103.7.7 Fire Alarm System Design Standards. Where an existing fire alarm system is upgraded or replaced, the devices shall be addressable. Fire alarm systems utilizing more than 20 smoke and/or heat detectors shall have analog initiating devices.

Exception: Existing systems need not comply unless the total building, or fire alarm system, remodel or expansion exceeds 30% of the building. When cumulative building, or fire alarm system, remodel or expansion initiated after the date of original fire alarm panel installation exceeds 50% of the building, or fire alarm system, the fire alarm system must comply within 18 months of permit application.

1103.7.7.1 Communication requirements. Refer to Section 907.6.6 for applicable requirements.

110. **Section 1203.1.3 is amended to read as follows:**

1203.1.3 Installation. Emergency power systems and standby power systems shall be installed in accordance with the International Building Code, NFPA 70, NFPA 110 and NFPA 111. Existing installations shall be maintained in accordance with the original approval, except as specified in Chapter 11.

111. **Section 1203.1 is amended by adding Section 1203.1.10 to read as follows:**

1203.1.10 Critical Operations Power Systems (COPS). For Critical Operations Power Systems necessary to maintain continuous power supply to facilities or parts of facilities that require continuous operation for the reasons of public safety, emergency management, national security, or business continuity, see NFPA 70.

112. **Section 1203.2 is amended to read as follows:**

1203.2 Where Required. Emergency and standby power systems shall be provided where required by Sections 1203.2.1 through 1203.2.26 or elsewhere identified in this code or any other referenced code.

113. **Section 1203.2.4 is amended to read as follows:**

1203.2.4 Emergency Voice/Alarm Communications Systems. Emergency power shall be provided for emergency voice/alarm communications systems in the following occupancies, or as specified elsewhere in this code, as required in Section 907.5.2.2.5. The system shall be capable of powering the required load for a duration of not less than 24 hours, as required in NFPA 72.

Covered and Open Malls, Section 907.2.20 and 914.2.3

Group A Occupancies, Sections 907.2.1 and 907.5.2.2.4.

Special Amusement Buildings, Section 907.2.12.3

High-rise Buildings, Section 907.2.13

Atriums, Section 907.2.14

Deep Underground Buildings, Section 907.2.19

114. **Section 1203.2.14 is amended to read as follows:**

1203.2.14 Means of Egress Illumination. Emergency power shall be provided for means of egress illumination in accordance with Sections 1008.3 and 1104.5.1. (90 minutes)

115. Section 1203.2.15 is amended to read as follows:

1203.2.15 Membrane Structures. Emergency power shall be provided for exit signs in temporary tents and membrane structures in accordance with Section 3103.12.6.1. (90 minutes) Standby power shall be provided for auxiliary inflation systems in permanent membrane structures in accordance with Section 2702 of the International Building Code. (4 hours) Auxiliary inflation systems shall be provided in temporary air-supported and air-inflated membrane structures in accordance with Section 3103.10.4.

116. **Section 1203.2.17 is amended to read as follows:**

1203.2.17 Smoke Control Systems. Standby power shall be provided for smoke control systems in the following occupancies, or as specified elsewhere in this code, as required in Section 909.11:

Covered Mall Building, International Building Code, Section 402.7

Atriums, International Building Code, Section 404.7

Underground Buildings, International Building Code, Section 405.8

Group I-3, International Building Code, Section 408.4.2

Stages, International Building Code, Section 410.3.7.2

Special Amusement Buildings (as applicable to Group A's), International Building Code, Section 411.1

Smoke Protected Seating, Section 1029.6.2.1

117. **Section 1203.2 is amended by adding Sections 1203.2.19, 1203.2.20, 1203.2.21, 1203.2.22, 1203.2.23, 1203.2.24, 1203.2.25, and 1203.2.26 to read as follows:**

1203.2.19 Covered and Open Mall Buildings. Emergency power shall be provided in accordance with Section 907.2.20 and 914.2.3.

1203.2.20 Airport Traffic Control Towers. A standby power system shall be provided in airport traffic control towers more than 65 ft. in height. Power shall be provided to the following equipment:

1. Pressurization equipment, mechanical equipment and lighting.
2. Elevator operating equipment.
3. Fire alarm and smoke detection systems.

1203.2.21 Smokeproof Enclosures and Stair Pressurization Alternative. Standby power shall be provided for smokeproof enclosures, stair pressurization alternative and associated automatic fire detection systems as required by the International Building Code, Section 909.20.6.2.

1203.2.22 Elevator Pressurization. Standby power shall be provided for elevator pressurization system as required by the International Building Code, Section 909.21.5.

1203.2.23 Elimination of Smoke Dampers in Shaft Penetrations. Standby power shall be provided when eliminating the smoke dampers in ducts penetrating shafts in accordance with the International Building Code Section 717.5.3, Exception 2.3.

1203.2.24 Common Exhaust Systems for Clothes Dryers. Standby power shall be provided for common exhaust systems for clothes dryers located in multistory structures in accordance with the International Mechanical Code, Section 504.10, Item 7.

1203.2.25 Hydrogen Cutoff Rooms. Standby power shall be provided for mechanical ventilation and gas detection systems of Hydrogen Cutoff Rooms in accordance with the International Building Code Section 421.8.

1203.2.26 Means of Egress Illumination in Existing Buildings. Emergency power shall be provided for means of egress illumination in accordance with Section 1104.5 when required by the fire code official. (90 minutes in I-2, 60 minutes elsewhere.)

118. **Section 1203 is amended by adding Section 1203.7 to read as follows:**

1203.7 Energy Time Duration. Unless a time limit is specified by the fire code official, in this chapter or elsewhere in this code, or in any other referenced code or standard, the emergency and standby power system shall be supplied with enough fuel or energy storage capacity for not less than 2-hour full-demand operation of the system.

Exception: Where the system is supplied with natural gas from a utility provider and is approved.

119. **Section 2304.1 is amended to read as follows:**

2304.1 Supervision of Dispensing. The dispensing of fuel at motor fuel-dispensing facilities shall be in accordance with the following:

1. Conducted by a qualified attendant; and/or,
2. Shall be under the supervision of a qualified attendant; and/or
3. Shall be an unattended self-service facility in accordance with Section 2304.3.

At any time the qualified attendant of Item 1 or 2 above is not present, such operations shall be considered as an unattended self-service facility and shall also comply with Section 2304.3.

120. **Section 2401.2 is deleted.**

121. **Section 3103.3.1 is deleted.**

122. **Table 3206.2 is amended by amending Footnotes “h” to read as follows:**

h. Where storage areas are protected by either early suppression fast response (ESFR) sprinkler systems or control mode special application sprinklers with a response time index of 50 (m • s) 1/2 or less that are listed to control a fire in the stored commodities with 12 or fewer sprinklers, installed in accordance with NFPA 13, manual smoke and heat vents or manually activated engineered mechanical smoke exhaust systems shall be required within these areas.

123. Table 3206.2 is amended by adding Footnote “j” to row titled ‘High Hazard’ and ‘Greater than 300,000’ to read as follows:

j. High hazard high-piled storage areas shall not exceed 500,000 square feet. A 2-hour fire wall constructed in accordance with Section 706 of the International Building Code shall be used to divide high-piled storage exceeding 500,000 square feet in area.

124. **Section 3310.1 is amended by adding the following sentence to the end of the section:**

When fire apparatus access roads are required to be installed for any structure or development, they shall be approved prior to the time at which construction has progressed beyond completion of the foundation of any structure.

125. **Section 5601.1.3 is amended to read in its entirety as follows:**

5601.1.3. Fireworks. The possession, manufacture, storage, sale, handling and use of fireworks are prohibited.

Exceptions:

1. Only when approved for fireworks displays, storage and handling of fireworks as allowed in Section 5604 and 5608.
2. The use of fireworks for approved displays as allowed in Section 5608.

126. **Section 5703.6 is amended by adding a sentence to read as follows:**

5703.6 Piping systems. Piping systems, and their component parts, for flammable and combustible liquids shall be in accordance with Sections 5703.6.1 through 5703.6.11. An approved method of secondary containment shall be provided for underground tank and piping systems.

127. Section 5704.2.11.4 is amended to read as follows:

5704.2.11.4 Leak Prevention. Leak prevention for underground tanks shall comply with Sections 5704.2.11.4.1 and 5704.2.11.5.2 through 5704.2.11.4.3. An approved method of secondary containment shall be provided for underground tank and piping systems.

128. **Section 5704.2.11.4.2 is amended to read as follows:**

5704.2.11.4.2 Leak detection. Underground storage tank systems shall be provided with an approved method of leak detection from any component of the system that is designed and installed in accordance with NFPA 30 and as specified in Section 5704.2.11.4.3.

129. **Section 5704.2.11.4.3 is amended to read as follows:**

5704.2.11.4.3 Observation Wells. Approved sampling tubes of a minimum 4 inches in diameter shall be installed in the backfill material of each underground flammable or combustible liquid storage tank. The tubes shall extend from a point 12 inches below the average grade of the excavation to ground level and shall be provided with suitable surface access caps. Each tank site shall provide a sampling tube at the corners of the excavation with a minimum of 4 tubes. Sampling tubes shall be placed in the product line excavation within 10 feet of the tank excavation and one every 50 feet routed along product lines towards the dispensers, a minimum of two are required.

130. Section 5707.4 is amended by adding the following paragraph:

Mobile fueling sites shall be restricted to commercial, industrial, governmental, or manufacturing, where the parking area having such operations is primarily intended for employee vehicles. Mobile fueling shall be conducted for fleet fueling or employee vehicles only, not the general public. Commercial sites shall be restricted to office-type or similar occupancies that are not primarily intended for use by the public.

131. **Section 6103.2.1 is amended by adding Section 6103.2.1.8 to read as follows:**

6103.2.1.8 Jewelry Repair, Dental Labs and Similar Occupancies. Where natural gas service is not available, portable LP-Gas containers are allowed to be used to supply approved torch assemblies or similar appliances. Such containers shall not exceed 20-pound (9.0 kg) water capacity. Aggregate capacity shall not exceed 60-pound (27.2 kg) water capacity. Each device shall be separated from other containers by a distance of not less than 20 feet.

132. Section 6104.2 is amended by adding Exception 2 read as follows:

2. Except as permitted in Sections 308 and 6104.3.2, LP-gas containers are not permitted in residential areas.

133. **Section 6104.3 is amended by adding Section 6104.3.2 to read as follows:**

6104.3.2 Spas, Pool Heaters, and Other Listed Devices. Where natural gas service is not available, an LP-gas container is allowed to be used to supply spa and pool heaters or other listed devices. Such container shall not exceed 250-gallon water capacity per lot. See Table 6104.3 for location of containers.

Exception: Lots where LP-gas can be off-loaded wholly on the property where the tank is located may install up to 500 gallon above ground or 1,000 gallon underground approved containers.

134. **Section 6107.4 is amended to read as follows:**

6107.4 Protecting Containers from Vehicles. Where exposed to vehicular damage due to proximity to alleys, driveways or parking areas, LP-gas containers, regulators and piping shall be protected in accordance with Section 312.

135. **Section 6109.13 is amended to read as follows:**

6109.13 Protection of Containers. LP-gas containers shall be stored within a suitable enclosure or otherwise protected against tampering. Vehicle impact protection shall be provided as required by Section 6107.4.

136. **Appendix L Requirements for Fire Fighter Air Replenishment Systems is amended by adding Section L101.2 to read as follows:**

Section L101.2 Required Location. In new buildings, fill stations shall be required when any of the following conditions occur:

1. Any new building 5 or more stories in height.
2. Any new building with 2 or more floors below grade.
3. Any new building 500,000 feet or more in size.

Each stairwell shall have a supply riser. SCBA fill stations shall be located on odd numbered floors in the primary stairwell and on even numbered stairs in the secondary stairwells. The primary stairwell will be the stair located closest to the main entrance.

Sec. 3.05. Amendments to the International Residential Code, 2018 edition.

The following amendments to the International Residential Code, 2015 edition, as adopted pursuant to Section 3.01, are hereby adopted:

1. **Section R102.4 is amended to read as follows:**

Section R102.4 Referenced codes and standards. The codes, when specifically adopted, and standards referenced in this code shall be considered part of the requirements of this code to the prescribed extent of each such reference and as further regulated in Sections R102.4.1 and R102.4.2. Whenever amendments have been adopted to the referenced codes and standards, each reference to said code and standard shall be considered to reference the amendments as well. Any reference made to NFPA 70 or the ICC Electrical Code shall mean the Electrical Code as adopted.

2. **Section 103 and R103.1 amend to insert the Department Name as follows:**

R103.1 Creation of enforcement agency. The City of Allen Building Inspection Department is hereby created and the official in charge thereof shall be known as the Building Official.

3. **Section R104.10.1 is deleted.**

4. **Section R105.2 is amended by deleting numbered paragraphs 1, 2, 3, 5, and 10 under the subparagraph titled "Building."**

5. **Section R105.3.1.1 is deleted.**

6. **Section R106.1.4 is deleted.**

7. **Section R108 is amended by adding Section R108.7 to read as follows:**

R108.7 Re-inspection fee. A fee as established by city council resolution may be charged when:

1. The inspection called for is not ready when the inspector arrives.
2. No building address or permit card is clearly posted.
3. Approved plans are not on the job site and available to the inspector at time of inspection.
4. The building is locked or work otherwise is not available for inspection when called.
5. The job site is red-tagged twice for the same item.
6. The original red tag has been removed from the job site.
7. Violations exist on the property including failure to maintain erosion control, trash control or tree protection.
8. Any re-inspection fees assessed shall be paid before additional inspections are conducted on that job site.

8. **Section R110 (inclusive of Sections R110.1 through R110.5) is deleted in its entirety.**

9. **Section R112 is amended in its entirety to read as follows:**

**Section R112
MEANS OF APPEAL**

R112.1 Application for appeal. Any person shall have the right to appeal a decision of the building official to the Board of Adjustment as provided in Section 2.02 of the Allen Land Development Code

10. **Section R202 is amended by amending the definition of “Townhouse” to read as follows:**

TOWNHOUSE. A single-family dwelling unit constructed in a group of three or more attached units separated by property lines in which each unit extends from foundation to roof and with a yard or public way on at least two sides.

11. **Table R301.2(1) is amended, to read as follows:**

**TABLE R301.2(1)
CLIMATIC AND GEOGRAPHIC DESIGN CRITERIA**

GROUND SNOW LOAD	WIND DESIGN				SEISMIC DESIGN CATEGORY ^f
	SPEED ^d (mph)	Topographic Effects ^k	Special Wind Region ^l	Windborne Debris Zone ^m	
5 lb/ft ²	115 (3 sec-gust)/76 fastest mile	No	No	No	A

SUBJECT TO DAMAGE FROM		
Weathering ^a	Frost line depth ^b	Termite ^c
Moderate	6"	Very Heavy

WINTER DESIGN TEMP ^e	ICE BARRIER UNDER-LAYMENT REQUIRED ^h	FLOOD HAZARDS ^g	AIR FREEZING INDEX ⁱ	MEAN ANNUAL TEMP ^j
22°F	No	Local Code	150	64.9°F

12. **Section R302.1 is amended by amending paragraph 4 and adding a new paragraph 6 under “Exceptions” to read as follows:**

Exceptions:

4. Detached garages accessory to a dwelling located within 5 feet of a lot line may have roof projections not exceeding 12 inches.
6. Open metal carport structures may be constructed within three (3) feet of the property line without fire-resistive or opening protection when the location of such is approved as required within adopted ordinances.

13. **Section R302.3; add Exception # 3 to read as follows:**

3. Two-family dwelling units that are also divided by a property line through the structure shall be separated as required for townhouses.

14. **Section R302.5.1 is amended to read as follows:**

R302.5.1 Opening protection. Openings from a private garage directly into a room used for sleeping purposes shall not be permitted. Other openings between the garage and residence shall be equipped with solid wood doors not less than 1 3/8 inches (35 mm) in thickness, solid or honeycomb core steel doors not less than 1 3/8 inches (35 mm) thick, or 20-minute fire rated doors.

15. **Section R302.7 is amended to read as follows:**

R302.7 Under stair protection. All enclosed space under stairs that have “No Access” shall have under stair surface of 5/8” fire-rated gypsum board and any soffits protected on the enclosed side with 5/8-inch (15.8 mm) fire-rated-gypsum board or one-hour fire-resistive construction.

16. **Section 303.3 is amended by amending only the last sentence of the paragraph titled “Exception” to read as follows:**

Exception: ... Spaces containing only a water closet or water closet and a lavatory may be ventilated with an approved mechanical recirculating fan or similar device designed to remove odors from the air.

17. **Section R310.2.2 and add sentence to read as follows:**

1. Second or Third story windows that are required for Emergency Escape and Rescue shall be provided with an Approved Fire Escape ladders.

18. **Section R313.2 One- and Two-Family Dwellings; Delete this section and subsection in their entirety.**

19. **Section R315.2.2 Alterations, repairs and additions; amend to read as follows:**

2. Installation, alteration or repairs of electrical powered mechanical systems or plumbing appliances.

20. **Section R322 is deleted.**

21. **Section R401.2 is amended by adding the following sentence at the end of the section:**

Every foundation and/or footing, or any size addition to an existing post-tension foundation, regulated by this code shall be designed and sealed by a Texas-registered engineer.

22. **Section R602.6.1 is amended to read as follows:**

R602.6.1 Drilling and notching of top plate. When piping or ductwork is placed in or partly in an exterior wall or interior load-bearing wall, necessitating cutting, drilling or notching of the top plate by more than 50 percent of its width, a galvanized metal tie not less than 0.054 inch thick (1.37 mm) (16 Ga) and 5 inches (127 mm) wide shall be fastened across and to the plate at each side of the opening with not less than eight 10d (0.148 inch diameter) having a minimum length of 1 ½ inches (38 mm) tie must extend a minimum of 6 inches past the opening. Fasteners will be offset to prevent splitting of the top plate material. The metal tie must extend a minimum of 6 inches past the opening. See figure R602.6.1. (“Exception” remains unchanged)

23. **Figure R602.6(1) is amended to appear and read as follows:**

Plumbing in walls and top plates. Any plumbing in a stud wall and top plate 2” and larger shall be installed in a 2” x 6” stud wall and top/bottom plates.

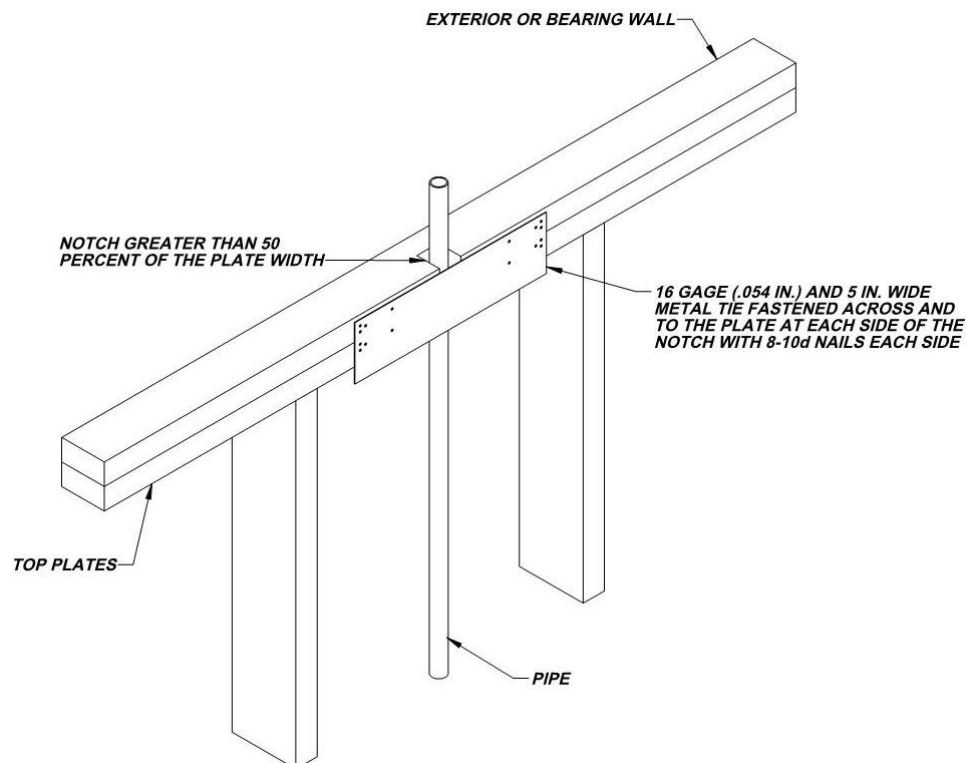

24. **Section R703.8.4.1 is amended by adding Section 703.8.4.1.2 to read as follows:**

R703.8.4.1.2 Veneer Ties for Wall Studs. In stud framed exterior walls, all ties shall be anchored to studs as follows:

1. When studs are 16 inches (407 mm) O.C., stud ties shall be spaced no further apart than 24 inches (737 mm) vertically starting approximately 12 inches (381 mm) from the foundation; or
2. When ties are placed on studs 24 inches (610 mm) O.C., stud ties shall be spaced no further apart than 16 inches (483 mm) vertically starting approximately 8 inches (254 mm) from the foundation.

25. **Section R806.3 is amended by adding Section R806.3.1 to read as follows:**

Section R806.3.1. Eave and cornice vents. Where eave or cornice vents are installed, they shall be a minimum of 3 feet from all window and door openings.

26. **Section R807.1 is amended by adding the following to the end of the second paragraph:**

Decking materials for walkway shall be of ½” minimum plywood or 5/8” minimum wafer board. A permanent ladder and/or stairways with a #300 lb. rating for access and removal of equipment shall be provided.

27. **Section R902.1 is amended by amending the first paragraph and adding a new paragraph 5 under “Exceptions” to read as follows:**

R902.1 Roofing covering materials. Roofs shall be covered with materials set forth in Sections R904 and R905. Class A, B, or C roofing shall be installed. Classes A, B, and C roofing required by this section to be listed shall be tested in accordance with UIL 790 or ASTM E 108.

Exceptions:

5. Non-classified roof coverings shall be permitted on one-story detached accessory structures used as tool and storage sheds, playhouses and similar uses, provided floor area is less than <120 square feet.

28. **CHAPTER 11 [RE] ENERGY EFFICIENCY is deleted in its entirety; Reference the 2018 IECC for energy code provisions and recommended amendments.**

29. **Section M1305.1.2 is amended, to read as follows:**

M1305.1.2 Appliances in attics. Attics containing appliances shall be provided . . . (*intervening text unchanged*) . . . sides of the appliance where access is required. The clear access opening dimensions shall be a minimum of 20 inches by 30 inches (508 mm by 762 mm), or larger and large enough to allow removal of the largest appliance. A walkway to an appliance shall be rated as a floor as approved by the building official. As a minimum, access to the attic space shall be provided by one of the following:

1. A permanent stair.
2. A pull down stair with a minimum 300 lb. (136kg) capacity.
3. An access door from an upper floor level.

4. Access panel may be used in lieu of items 1, 2, and 3 with prior approval of the building official due to building conditions.

Exceptions:

1. The passageway and level service space are not required where the appliance can be serviced and removed through the required opening.
2. Where the passageway is unobstructed ... *{remaining text unchanged}*

30. **Section M1401.4 is amended to read as follows:**

M1401.4 Exterior installations. Equipment and appliances installed outdoors shall be listed and labeled for outdoor installation. No a/c condensers shall be located in side yards less than 7 feet, unless approved by the Building Official. *{remaining text unchanged.}*

31. **Section M1411.3 is amended to read as follows:**

M1411.3 Condensate disposal. Condensate from all cooling coils or evaporators shall be conveyed from the drain pan outlet to a sanitary sewer through a trap, by means of a direct or indirect drain. *{remaining text unchanged}*

32. **Section M1411.3.1 is amended by adding Items 3 and 4 to read as follows:**

3. An auxiliary drain pan... (intervening text unchanged) ...with item 1 of this section. A water level detection/shut off device may be installed only with prior approval of the building official.
4. A water level detection device... *(intervening text unchanged)* overflow rim of such pan. A water level detection/shut off device may be installed with prior approval of the building official.

33. **Section M1411.3.1.1 is amended to read as follows:**

M1411.3.1.1 Water-level monitoring devices. On down-flow units... *(bulk of text unchanged)* installed in the drain line. A water level detection device may be installed only with prior approval of the building official.

34. **Section M1503.6 Makeup Air Required is amend to read as follows:**

M1503.6 Makeup air required. Where one or more gas, liquid or solid fuel-burning appliance that is neither direct-vent nor uses a mechanical draft venting system is located within a dwelling unit's air barrier, each exhaust system capable of exhausting in excess of 400 cubic feet per minute (0.19 m³/s) shall be mechanically or passively provided with makeup air at a rate approximately equal to the difference between the exhaust air rate and 400 cubic feet per minute. Such makeup air systems shall be equipped with not fewer than one damper complying with Section M1503.6.2.

Exception: Make up air is not required for exhaust systems installed for the exclusive purpose of space cooling and intended to be operated only when windows or other air inlets are open. Where all appliances in the house are of sealed combustion, power-vent, unvented, or electric, the exhaust hood system shall be permitted to exhaust up to 600 cubic feet per minute (0.28 m³/s) without providing makeup air. Exhaust hood systems capable of exhausting in excess of 600 cubic feet per minute (0.28 m³/s) shall be provided with a makeup air at a rate of approximately equal to the difference between the exhaust air rate and 600 cubic feet per minute.

35. **Section M1601.4.4 is amended to read as follows:**

M1601.4.4 Support. Metal ducts listed in accordance with UL 181 shall be supported in accordance with manufacturer's installation instructions or other approved means. Flexible ducts shall be supported by 1-inch wide 18-gauge solid metal straps with 6" metal saddles at intervals not exceeding 10 feet or in accordance with the manufacturer's installation instructions.

36. **Section M2005.2 is amended to read as follows:**

M2005.2 Prohibited locations. Fuel-fired water heaters shall not be installed in a room used as a storage closet. Water heaters located in a bedroom or bathroom shall be installed in a sealed enclosure so that combustion air will not be taken from the living space. Access to such enclosure may be from the bedroom or bathroom when through a solid door, weather-stripped in accordance with the exterior door air leakage requirements of the International Energy Conservation Code and equipped with an approved self-closing device. Installation of direct-vent water heaters within an enclosure is not required. ***No tank type water heaters shall be permitted to be installed in New Residential attics.*** Tank less type water heater(s) shall be approved for attic installation and shall require a pan and drain the T&P line directly to the outdoor or approved location.

37. **Section G2404.1 (301.1) is amended by adding the following sentence to the end of the section:**

All gas meters shall be located on the structure.

38. **Section G2408.3 (305.5) is deleted.**

39. **Section G2415.2.1 (404.2.1) is amended by adding a second paragraph to read as follows:**

Both ends of each section of medium pressure gas piping shall identify its operating gas pressure with an *approved* tag. The tags are to be composed of aluminum or stainless steel and the following wording shall be stamped into the tag:

"WARNING: 1/2 to 5 psi gas pressure - Do Not Remove"

40. **Section G2415.2.2 (404.2.2) is amended by adding a paragraph titled "Exception" to read as follows:**

Exception: Corrugated stainless steel tubing (CSST) shall be a minimum of 1/2" (18 EDH).

41. **Section 2415.12 (404.12) is amended to read as follows:**

G2415.12 (404.12) Minimum burial depth. Underground piping systems shall be installed a minimum depth of 18 inches (457 mm) below grade.

42. **G2415.12.1 (404.12.1) is deleted.**

43. **Section G2417.1 (406.1) is amended to read as follows:**

G2417.1 (406.1) General. Prior to acceptance and initial operation, all piping installations shall be inspected and pressure tested to determine that the materials, design, fabrication, and installation practices comply with the requirements of this Code. The permit holder shall make the applicable tests prescribed in Sections 2417.1.1 through 2417.1.5 to determine compliance with the provisions of this Code. The permit holder shall give reasonable advance notice to the building official when the piping system is ready for testing. The equipment, material, power and labor necessary for the inspections

and test shall be furnished by the permit holder and the permit holder shall be responsible for determining that the work will withstand the test pressure prescribed in the following tests. The pressure test will require a diaphragm gauge that has been certified annually and the system tested through its entirety and with All stops open.

44. **Section G2417.4 is amended to read as follows:**

G2417.4 (406.4) Test pressure measurement. Test pressure shall be measured with a manometer or with a pressure-measuring device designed and calibrated to read, record, or indicate a pressure loss caused by leakage during the pressure test period. The source of pressure shall be isolated before the pressure tests are made.

45. **Section G2417.4.1 is amended to read as follows:**

G2417.4.1 (406.4.1) Test pressure. The test pressure to be used shall be not less than 3 psig (20 kPa gauge), or at the discretion of the building official, the piping and valves may be tested at a pressure of at least six (6) inches (152 mm) of mercury, measured with a manometer or slope gauge. For tests requiring a pressure of 3 psig, diaphragm gauges shall utilize a dial with a minimum diameter of three and one half inches (3 1/2"), a set hand, 1/10 pound incrementation and pressure range not to exceed 6 psi for test requiring a pressure of 3 psig. For tests requiring a pressure of 10 psig, diaphragm gauges shall utilize a dial with a minimum diameter of three and one-half inches (3 1/2"), a set hand, a minimum of 2/10 pound incrementation and a pressure range not to exceed 20 psi. For welded piping, and for piping carrying gas at pressures in excess of fourteen (14) inches water column pressure (3.48 kPa) (1/2 psia) and less than 200 inches of water column pressure (52.2 kPa) (7.5 psi), the test pressure shall not be less than ten (10) pounds per square inch (69.6 kPa). For piping carrying gas at a pressure that exceeds 200 inches of water column (52.2 kPa) (7.5 psi), the test pressure shall be not less than one and one-half times the proposed maximum working pressure.

Diaphragm gauges used for testing must display a current calibration and be in good working condition. The appropriate test must be applied to the diaphragm gauge used for testing.

46. **Section G2417.4.2 is amended to read as follows:**

G2417.4.2 (406.4.2) Test duration. Test duration shall be held for a length of time satisfactory to the building official, but in no case for less than fifteen (15) minutes. For welded piping, and for piping carrying gas at pressures in excess of fourteen (14) inches water column pressure (3.48 kPa), the test duration shall be held for a length of time satisfactory to the building official, but in no case for less than thirty (30) minutes. The test shall be through the entire system with All stops open.

47. **Section G2420.1 (406.1) is amended by adding Section G2420.1.4 to read as follows:**

G2420.1.4 Valves in CSST installations. Shutoff valves installed with corrugated stainless steel (CSST) piping systems shall be supported with an approved termination fitting, or equivalent support, suitable for the size of the valves, of adequate strength and quality, and located at intervals so as to prevent or damp out excessive vibration but in no case greater than 12-inches from the center of the valve. Supports shall be installed so as not to interfere with the free expansion and contraction of the system's piping, fittings, and valves between anchors. All valves and supports shall be designed and installed so they will not be disengaged by movement of the supporting piping.

48. **Section G2420.5.1 (409.5.1) is amended to read as follows:**

G2420.5.1 (409.5.1) Located within the same room. The shutoff valve.... (*intervening text unchanged*) ...in accordance with the appliance manufacturer's instructions. A secondary shutoff valve must be installed within 3 feet (914 mm) of the firebox if appliance shutoff is located in the firebox.

49. **Section G2421.1 (410.1) is amended to read as follows:**

G2421.1 (410.1) Pressure regulators. A line pressure regulator shall be... (*intervening text unchanged*) ... approved for outdoor installation. Access to regulators shall comply with requirements for access to appliances as specified in Section M1305.

Exception: A passageway or level service space is not required when the regulator is capable of being serviced and removed through the required attic opening.

50. **Section G2445.2 (621.2) is amended by adding a paragraph titled “Exception” to read as follows:**

G2445.2 (621.2) Prohibited use. One or more unvented room heaters shall not be used as the sole source of comfort heating in a dwelling unit.

Exception: Existing approved unvented heaters may continue to be used in *dwelling units*, in accordance with the code provisions in effect when installed, when approved by the building official unless an unsafe condition is determined to exist as described in International Fuel Gas Code Section 108.7 of the Fuel Gas Code.

51. **Section G2448.1.1 (624.1.1) is amended to read as follows:**

G2448.1.1 (624.1.1) Installation requirements. The requirements for water heaters relative to access, sizing, relief valves, drain pans and scald protection shall be in accordance with this code.

52. **Section 2602.1 is amended by amending the paragraph titled “Exception” to read as follows:**

Exception: Sanitary drainage systems that were installed with a septic tank or septic system, upon failure or need of repair must be connected to the City Sanitary Sewer System.

53. **Section P2603.3 is amended to read as follows:**

P2603.3 Protection against corrosion. Metallic piping, except for cast iron, ductile iron and galvanized steel, shall not be placed in direct contact with steel framing members, concrete or cinder walls and floors or other masonry. Metallic piping shall not be placed in direct contact with corrosive soil. Where sheathing is used to prevent direct contact, the sheathing shall have a thickness of not less than 0.008 inch (8 mil) (0.203 mm) and the sheathing shall be made of approved material. Where sheathing protects piping that penetrates concrete or masonry walls or floors, the sheathing shall be installed in a manner that allows movement of the piping within the sheathing.

54. **Section P2603.5.1 is amended to read as follows:**

P2603.5.1 Sewer depth. Building sewers that connect to private sewage disposal systems shall be a minimum of 12 inches (304 mm) below finished grade at the point of septic tank connection. Building sewers shall be a minimum of 12 inches (304 mm) below grade.

55. **Section P2604.2 is amended by adding Section P2604.2.1 to read as follows:**

P2604.2.1 Plastic sewer and DWV piping installation. Plastic sewer and DWV piping installed underground shall be installed in accordance with the manufacturer’s installation instructions. Trench width shall be controlled to not exceed the outside the pipe diameter plus 16 inches or in a trench which has a controlled width equal to the nominal diameter of the piping multiplied by 1.25 plus 12 inches. The piping shall be bedded in 4 inches of granular fill and then backfilled compacting the side fill in 6-

inch layers on each side of the piping. The compaction shall be to minimum of 85 percent standard proctor density and extend to a minimum of 6 inches above the top of the pipe.

56. **Section P2718.1 is amended by adding new Section P2718.1.1 to read as follows:**

Section P2718.1.1; Pan required. All clothes washing machines on a second floor or above shall have a pan. The pan shall be tested with a water test during construction and exit the exterior of the structure to the outside.

57. **Section P2801.5 is amended to read as follows:**

Section P2801.5 Prohibited locations. Water heaters shall be located in accordance with Chapter 20. No tank type water heaters shall be permitted to be installed in New Residential attics. Tank less water heater(s) may be approved for attic installation and shall require a pan and drain the T&P line directly to the outdoor or approved location.

58. **Section P2801.6.1 is amended to read as follows:**

P2801.6.1 Pan size and drain. The pan shall be not less than 1 1/2 inches (38 mm) in depth and shall be of sufficient size and shape to receive all dripping or condensate from the tank or water heater. The pan shall be drained by an indirect waste pipe having a diameter of not less than 3/4 inch (19 mm). Piping for safety pan drains shall be of those materials listed in Table 605.4. Multiple pan drains may terminate to a single discharge piping system when approved by the administrative authority and permitted by the manufacturer's installation instructions and installed with those instructions.

59. **Section P2801.7 is amended by adding an "Exception" to read as follows:**

Exception: Electric Water Heater.

60. **Section P2804.6.1 is amended to read as follows:**

P2804.6.1; Requirements for discharge piping. The discharge piping serving a pressure relief valve, temperature relief valve or combination thereof shall:

1. Not be directly connected to the drainage system.
2. Discharge through an air gap.
3. Not be smaller than the diameter of the outlet of the valve served and shall discharge full size to the air gap.
4. Serve a single relief device and shall not connect to piping serving any other relief device or equipment.

Exception: Multiple relief devices may be installed to a single T & P discharge piping system when approved by the administrative authority and permitted by the manufacturer's installation instructions and installed with those instructions.

5. Discharge to an indirect waste receptor or to the outdoors.

(remaining text is unchanged)

61. **Section P2902.5.3 is amended to read as follows:**

P2902.5.3 Lawn Irrigation Systems. The potable water supply system to lawn irrigation systems shall be protected against backflow by an atmospheric-type vacuum breaker, a pressure-type vacuum breaker, a double-check assembly or a reduced pressure principle backflow preventer. A valve shall not be installed downstream from an atmospheric vacuum breaker. Where chemicals are introduced into the system, the potable water supply shall be protected against backflow by a reduced pressure principle backflow preventer. All irrigation systems shall have rain and freeze protection installed.

62. **Section 3003.9.2 is amended to read in its entirety as follows:**

P3003.9.2 Solvent cementing. Joint surfaces shall be clean and free from moisture. A purple primer that conforms to ASTM F656 shall be applied. Solvent cement not purple in color and conforming to ASTM D2564, CSA B137.3, CSA B181.2 or CSA B182.1 shall be applied to all joint surfaces. The joint shall be made while the cement is wet and shall be in accordance with ASTM D2855. Solvent cement joints shall be permitted above or below ground.

63. **P3005.2.1 is amended to read as follows:**

P3005.2.1 Horizontal drains and building drains. Horizontal drainage pipes in buildings shall have cleanouts located at intervals of not more than 75 feet. Building drains shall have cleanouts located at intervals not more than 75 feet except where manholes... *{remaining text unchanged}*.

64. **Section P3101.2.1 is amended to read as follows:**

Section P3101.2.1 Venting, No flat venting permitted.

65. **Section P3111, including all subsections, is deleted in its entirety.**

66. **Section 3112.2 is amended in its entirety to read as follows:**

P3112.2 Installation. Traps for island sinks and similar equipment shall be roughed in above the floor and may be vented by extending the vent as high as possible, but not less than the drainboard height and then returning it downward and connecting it to the horizontal sink drain immediately downstream from the vertical fixture drain. The return vent shall be connected to the horizontal drain through a wye-branch fitting and shall, in addition, be provided with a foot vent taken off the vertical fixture vent by means of a wye-branch immediately below the floor and extending to the nearest partition and then through the roof to the open air or may be connected to other vents at a point not less than six (6) inches (152 mm) above the flood level rim of the fixtures served. Drainage fittings shall be used on all parts of the vent below the floor level and a minimum slope of one-quarter (1/4) inch per foot (20.9 mm/m) back to the drain shall be maintained. The return bend used under the drainboard shall be a one (1) piece fitting or an assembly of a forty-five (45) degree (0.79 radius), a ninety (90) degree (1.6 radius) and a forty-five (45) degree (0.79 radius) elbow in the order named. Pipe sizing shall be as elsewhere required in this Code. The island sink drain, upstream of the return vent, shall serve no other fixtures. An accessible cleanout shall be installed in the vertical portion of the foot vent.

Sec. 3.06 Amendments to International Mechanical Code, 2018 edition.

The following amendments to the International Mechanical Code, 2018 edition, as adopted pursuant to Section 3.01, are hereby adopted:

1. **Section 102.8 is amended to read as follows:**

102.8 Referenced codes and standards. The codes and standards referenced herein shall be those that are listed in Chapter 15 and such codes, when specifically adopted, and standards shall be considered part of the requirements of this code to the prescribed extent of each such reference. Where differences

occur between provisions of this code and the referenced standards, the provisions of this code shall apply. Whenever amendments have been adopted to the referenced codes and standards, each reference to said code and standard shall be considered to reference the amendments as well. Any reference to NFPA 70 or the ICC *Electrical Code* shall mean the Electrical Code as adopted.

2. **Sections 106.5.2 and 106.5.3 are amended to read as follows:**

106.5.2 Fee schedule. Fees for the issuance of permits and performance of inspections as required by this code shall be as established from time to time by resolution of the City Council and set forth in the City's Fee Schedule

106.5.3 Fee refunds. The building official shall establish a policy for authorizing the refunding of fees.

3. **Section 306.3 is amended to read as follows:**

306.3 Appliances in attics. Attics containing appliances shall be provided ... *{intervening language unchanged}* ... side of the appliance. The clear access opening dimensions shall be a minimum of 20 inches by 30 inches (508 mm by 762 mm), or larger where such dimensions are not large enough to allow removal of the largest appliance, shall have continuous solid flooring with a minimum thickness of ½" plywood or 5/8" wafer board, and shall be placed over a load bearing wall or with engineered approval. A walkway to an appliance shall be rated as a floor as approved by the building official. At a minimum, for access to the attic space, provide one of the following:

1. A permanent stair.
2. A pull-down stair with a minimum 300 lbs. (136 kg) capacity.
3. An access door from an upper floor level.
4. Access panel may be used in lieu of items 1, 2, and 3 with prior approval of the code official due to building conditions.

Exceptions:

1. The passageway and level service space are not required where the appliance is capable of being serviced and removed through the required opening.
2. Where the passageway is not less than... *{remainder of section unchanged}*.

A receptacle outlet shall be provided at or near the equipment and appliance location within 25 feet and in accordance with the Electrical Code.

4. **Section 306.5 is amended to read as follows:**

306.5 Equipment and appliances on roofs or elevated structures. Where *equipment* requiring *access* or appliances are located on an elevated structure or the roof of a building such that personnel will have to climb higher than 16 feet (4877 mm) above grade to access a permanent interior or exterior means of access shall be provided. Permanent exterior ladders providing roof access need not extend closer than 12 feet (2438 mm) to the finish grade or floor level below and shall extend to the equipment and appliances' level service space. Such access shall... *{intervening language unchanged}* ...on roofs having a slope greater than 4 unit's vertical in 12 unit's horizontal (33-percent slope) ... *{remaining text unchanged}*.

A receptacle outlet shall be provided at or near the equipment and appliance location within 25 feet and in accordance with the Electrical Code.

5. **Section 306.5.1 is amended to read as follows:**

306.5.1 Sloped roofs. Where appliances, equipment, fans or other components that require service are installed on roofs having a slope of 3 unit's vertical in 12 units horizontal or greater and having an edge more than 30 inches (762 mm) above grade at such edge, a catwalk at least 16 inches in width with substantial cleats spaced not more than 16 inches apart shall be provided from the roof access to a level platform at the appliance. The level platform shall be provided on each side of the appliance to which access is required for service, repair or maintenance. The platform shall be not less than 30 inches (762 mm) in any dimension and shall be provided with guards. The guards shall extend not less than 42 inches (1067 mm) above the platform, shall be constructed so as to prevent the passage of a 21-inch-diameter (533 mm) sphere and shall comply with the loading requirements for guards specified in the *International Building Code*.

6. **Section 306 is amended by adding Section 306.6 to read as follows:**

306.6 Water heaters above ground or floor. When the mezzanine or platform in which a water heater is installed is more than eight (8) feet (2438 mm) above the ground or floor level, it shall be made accessible by a stairway or permanent ladder fastened to the building.

Exception: A maximum 10-gallon water heater (or larger with approval) is capable of being accessed through a lay-in ceiling and a water heater is installed is not more than ten (10) feet (3048 mm) above the ground or floor level and may be reached with a portable ladder.

306.6.1 Inadequate lighting at location. Whenever the mezzanine or platform is not adequately lighted or *access* to a receptacle outlet is not obtainable from the main level, lighting and a receptacle outlet shall be provided in accordance with Section 306.3.1.

7. **Section 307.2.3 is amended by amending numbered paragraph 2 to read as follows:**

2. A separate overflow drain line shall be connected to the drain pan provided with the equipment. Such overflow drain shall discharge to a conspicuous point of disposal to alert occupants in the event of a stoppage of the primary drain. The overflow drain line shall connect to the drain pan at a higher level than the primary drain connection. However, the conspicuous point shall not create a hazard such as dripping over a walking surface or other areas so as to create a nuisance.

8. **Section 403.2.1 is amended by adding paragraph 5 to read as follows:**

5. Toilet rooms within private dwellings that contain only a water closet, lavatory or combination thereof may be ventilated with an *approved* mechanical recirculating fan or similar device designed to remove odors from the air.

9. **Section 501.3 is amended by adding paragraph 4 under "Exceptions" to read as follows:**

4. Toilet room exhaust ducts may terminate in a warehouse or shop area when infiltration of outside air is present.

10. **Section 505.1 is amended to read as follows**

505.1 General. Domestic cooking exhaust equipment shall comply with the requirements of this section. All domestic cooking exhaust equipment ventilation shall be made vertical through the roof and shall not be permitted horizontal.

11. **Section 506.1 is amended to read as follows:**

506.1 General. Commercial kitchen hood ventilation ducts and exhaust *equipment* shall comply with the requirements of this section. All commercial cooking exhaust equipment ventilation shall be made vertical through the roof and Shall not be permitted horizontal. Type I and Type II hoods.

12. **Section 603.6.1.1 is amended to read as follows:**

603.6.1.1 Duct length. Flexible air ducts shall be a maximum of 5' (feet) and are required to have 1" (inch) solid metal straps and 6" (inch) metal saddles.

13. **Section 607.5.1 is amended to read as follows:**

607.5.1 Fire Walls. Ducts and air transfer openings permitted in fire walls in accordance with Section 706.11 of the *International Building Code* shall be protected with listed fire dampers installed in accordance with their listing. For hazardous exhaust systems see Section 510.1-510.9 IMC.

Sec. 3.07. Amendments to the International Fuel Gas Code, 2018 edition.

The following amendments to the International Fuel Gas Code, 2018 edition, as adopted pursuant to Section 3.01, are hereby adopted:

1. **Section 102.2 is amended by adding a paragraph titled "Exception" to read as follows:**

Exception: Existing dwelling units shall comply with Section 621.2.

2. **Section 102.8 is amended to read as follows:**

102.8 Referenced codes and standards. The codes and standards referenced in this code shall be those that are listed in Chapter 8 and such codes, when specifically adopted, and standards shall be considered part of the requirements of this code to the prescribed extent of each such reference. Where differences occur between provisions of this code and the referenced standards, the provisions of this code shall apply. Whenever amendments have been adopted to the referenced codes and standards, each reference to said code and standard shall be considered to reference the amendments as well. Any reference to NFPA 70 or the ICC Electrical Code shall mean the Electrical Code as adopted.

3. **Sections 106.6.2 and 106.6.3 are amended to read as follows:**

106.6.2, Fees. Fees for the issuance of permits and performance of inspections as required by this code shall be as established from time to time by resolution of the City Council and set forth in the City's Fee Schedule.

106.6.3 Fee refunds. The building official shall establish a policy for authorizing the refunding of fees.

4. **Section 109 is amended in its entirety to read as follows:**

**Section 109
MEANS OF APPEAL**

109.1 Application for appeal. Any person shall have the right to appeal a decision of the building official to the Board of Adjustment as provided in Section 2.02 of the Allen Land Development Code.

5. **Section 306.3 is amended to read in its entirety as follows:**

[M] 306.3 Appliances in attics. Attics containing appliances shall be provided...*{intervening language unchanged}*... side of the appliance. The clear access opening dimensions shall be a minimum of 20 inches by 30 inches (508mm by 762mm) or larger where such dimensions are not large enough to allow removal of the largest appliance. A walkway to an appliance shall be rated as a floor as approved by the building official, shall have continuous solid flooring with a minimum thickness of ½” plywood or 5/8” wafer board, and shall be placed over a load bearing wall or with engineered approval. As a minimum, for access to the attic space, provide one of the following:

- 1 A permanent stair.
2. A pull-down stair with a minimum 300 lbs. (136 kg) capacity.
3. An access door from an upper floor level.
4. Access Panel may be used in lieu of items 1, 2, and 3 with prior approval of the code official due to building conditions.

Exceptions:

1. The passageway and level service space are not required where the appliance is capable of being serviced and removed through the required opening.
2. Where the passageway is not less than ...*{remainder of section unchanged}*.

A receptacle outlet shall be provided at or near the equipment and appliance location within 25 feet and in accordance with the Electrical Code.

6. **Section 306.5 is amended to read as follows:**

[M]306.5 Equipment and appliances on roofs or elevated structures. Where *equipment* requiring *access* or appliances are located on an elevated structure or the roof of a building such that personnel will have to climb higher than 16 feet (4877) above grade to access, a permanent interior or exterior means of access shall be provided. Permanent exterior ladders providing roof access need not extend closer than 12 feet (2438 mm) to the finish grade or floor level below and shall extend to the equipment and appliances’ level service space. Such access shall... *{intervening language unchanged}*...on roofs having a slope greater than 4 units vertical in 12 units horizontal (33-percent slope)... *{remainder of section unchanged}*. A receptacle outlet shall be provided at or near the equipment and appliance location within 25 feet and in accordance with the Electrical Code.

7. **Section 306.5.1 is amended to read as follows:**

[M]306.5.1 Sloped roofs. Where appliances, equipment, fans or other components that require service are installed on roofs having slopes greater than 3 units vertical in 12 units horizontal (25-percent slope) or greater and having an edge more than 30 inches (762mm) above grade at such edge, a catwalk at least 16 inches in width with substantial cleats spaced not more than 16 inches apart shall be provided from the roof access to a level platform at the appliance. The level platform shall be provided on each side of the appliance to which access is required for service, repair or maintenance. The platform shall be not less than 30 inches (762 mm) in any dimension and shall be provided with guards. The guards shall extend not less than 42 inches (1067 mm) above the platform, shall be constructed so as to prevent the passage of a 21inch diameter (533 mm) sphere and shall comply with the loading requirements for guards specified in the *International Building Code*.

8. **Section 306 is amended by adding Section 306.7 and Subsection 306.7.1 to read as follows:**

306.7 Water heaters above ground floor. When the attic, roof, mezzanine or platform in which a water heater is installed is more than eight (8) feet (2438 mm) above the ground or floor level, it shall be made accessible by a stairway or permanent ladder fastened to the building.

306.7.1 Illumination and convenience outlet. Whenever the mezzanine or platform is not adequately lighted or access to a receptacle outlet is not obtainable from the main level, lighting and a receptacle outlet shall be provided in accordance with Section 306.3.1.

9. **Section 401.5 is amended by adding the following sentence at the end of the section:**

Both ends of each section of medium pressure gas piping shall identify its operating gas pressure with an *approved* tag. The tags are to be composed of aluminum or stainless steel and the following wording shall be stamped into the tag:

"WARNING
1/2 to 5 psi gas pressure
Do Not Remove"

10. **Section 404.12 is amended to read as follows:**

404.12 Minimum burial depth. Underground piping systems shall be installed a minimum depth of 18 inches (458 mm) top of pipe below grade.

11. **Section 404.12.1 is deleted.**

12. **Section 406.4 is amended to read as follows:**

406.4 Test pressure measurement. Test pressure shall be measured with a manometer or with a pressure-measuring device designed and calibrated to read, record, or indicate a pressure loss caused by leakage during the pressure test period. The source of pressure shall be isolated before the pressure tests are made.

13. **Section 406.4.1 is amended to read as follows:**

406.4.1 Test pressure. The test pressure to be used shall be not less than 3 psig (20 kPa gauge), or at the discretion of the Code official, the piping and valves may be tested at a pressure of at least six (6) inches (152 mm) of mercury, measured with a manometer or slope gauge. For tests requiring a pressure of 3 psig, diaphragm gauges shall utilize a dial with a minimum diameter of three and one half inches (3 ½"), a set hand, 1/10 pound incrementation and pressure range not to exceed 6 psi for tests requiring a pressure of 3 psig. For tests requiring a pressure of 10 psig, diaphragm gauges shall utilize a dial with a minimum diameter of three and one-half inches (3 ½"), a set hand, a minimum of 2/10 pound incrementation and a pressure range not to exceed 20 psi. For welded piping, and for piping carrying gas at pressures in excess of fourteen (14) inches water column pressure (3.48 kPa) (1/2 psi) and less than 200 inches of water column pressure (52.2 kPa) (7.5 psi) the test pressure shall not be less than ten (10) pounds per square inch (69.6 kPa). For piping carrying gas at a pressure that exceed 200 inches of water column (52.2 kPa) (7.5 psi) the test pressure shall be not less than one and one-half times the proposed maximum working pressure. Diaphragm gauges used for testing must display a current calibration and be in good working condition. The appropriate test must be applied to the diaphragm gauge used for testing. All diaphragm gauges must be tested and certified annually.

14. **Section 409.1.3 is amended to read as follows:**

409.1.3 Access to shut off valves. Shut off valves shall be located in places so as to provide *access* for operation and shall be installed so as to be protected from damage. All shut off valves in commercial kitchen installations shall be located no more than 6' (feet) from floor level with a ball valve for emergency shutoff.

15. **Section 409 is amended by adding Section 409.1.4 to read as follows:**

409.1.4 Valves in CSST installations. Shutoff valves installed with corrugated stainless steel (CSST) piping systems shall be supported with an *approved* termination fitting, or equivalent support, suitable for the size of the valves, of adequate strength and quality, and located at intervals so as to prevent or damp out excessive vibration but in no case greater than 12-inches from the center of the valve. Supports shall be installed so as not to interfere with the free expansion and contraction of the system's piping, fittings, and valves between anchors. All valves and supports shall be designed and installed so they will not be disengaged by movement of the supporting piping.

16. **Section 410.1 is amended by adding the following sentence at the end of the section and a paragraph titled "Exception" to read as follows:**

...Access to regulators shall comply with the requirements for access to appliances as specified in Section 306.

Exception: A passageway or level service space is not required when the regulator is capable of being serviced and removed through the required attic opening.

17. **Section 621.2 is amended by adding a paragraph titled "Exception" to read as follows:**

621.2 Prohibited use. One or more unvented room heaters may continue to be used in dwelling units, in accordance with the code provisions in effect when installed, when approved by the Code Official unless an unsafe condition is determined to exist as described in Section 108.7.

Exception: Existing *approved* unvented heaters may continue to be used in dwelling units, in accordance with the code provisions in effect when installed, when *approved* by the code official unless an unsafe condition is determined to exist as described in Section 108.7.

Sec. 3.08. Amendments to the International Plumbing Code, 2018 edition.

The following amendments to the International Plumbing Code, 2018 edition, as adopted pursuant to Section 3.01, are hereby adopted:

1. **Table of Contents, Chapter 7, Section 714 is amended to read as follows:**

714 Engineered Drainage Design 69

2. **Section 102.8 is amended to read as follows:**

102.8 Referenced codes and standards. The codes and standards referenced in this code shall be those that are listed in Chapter 15 and such codes, when specifically adopted, and standards shall be considered as part of the requirements of this code to the prescribed extent of each such reference. Where the differences occur between provisions of this code and the referenced standards, the provisions of this code shall be the minimum requirements. Whenever amendments have been adopted to the referenced codes and standards, each reference to said code and standard shall be considered to reference the adopted amendments as well. Any reference to NFPA 70 or the ICC *Electrical Code* shall mean the Electrical Code as adopted.

3. **Sections 106.6.2 and 106.6.3 are amended to read as follows:**

106.6.2 Fee schedule. Fees for the issuance of permits and performance of inspections as required by this code shall be as established from time to time by resolution of the City Council and set forth in the City's Fee Schedule.

106.6.3 Fee refunds. The building official shall establish a policy for authorizing the refunding of fees.

4. **Section 109 is amended in its entirety to read as follows:**

**SECTION 109
MEANS OF APPEAL**

109.1 Application for appeal. Any person shall have the right to appeal a decision of the building official to the Board of Adjustment as provided in Section 2.02 of the Allen Land Development Code.

5. **Section 305.1 is amended to read as follows:**

305.1 Protection against contact. Metallic piping, except for cast iron, ductile iron and galvanized steel, shall not be placed in direct contact with steel framing members, concrete or cinder walls and floors or other masonry. Metallic piping shall not be placed in direct contact with corrosive soil. Where sheathing is used to prevent direct contact, the sheathing shall have a thickness of not less than 0.008 inch (8 mil) (0.203 mm) and the sheathing shall be made of approved material. Where sheathing protects piping that penetrates concrete or masonry walls or floors, the sheathing shall be installed in a manner that allows movement of the piping within the sheathing.

6. **Section 305.4.1 is amended to read as follows:**

305.4.1 Sewer depth. Building sewers shall be a minimum of 12 inches (304 mm) below grade.

7. **Section 305.7 is amended to read as follows:**

305.7 Protection of components of plumbing system. Components of a plumbing system installed within 3 feet along alleyways, driveways, parking garages or other locations in a manner in which they could be exposed to damage shall be recessed into the wall or otherwise protected in an *approved* manner.

8. **Section 306 is amended by adding Section 306.2.4 to read as follows:**

306.2.4 Plastic sewer and DWV piping installation. Plastic sewer and DWV piping installed underground shall be installed in accordance with the manufacturer's installation instructions. Trench width shall be controlled to not exceed the outside the pipe diameter plus 16 inches or in a trench which has a controlled width equal to the nominal diameter of the diameter of the piping multiplied by 1.25 plus 12 inches. The piping shall be bedded in 4 inches of granular fill and then backfilled compacting the side fill in 6-inch layers on each side of the piping. The compaction shall be to minimum of 85 percent standard proctor density and extend to a minimum of 6 inches above the top of the pipe. All PBVC shall be schedule 40 with No Foam or Cell Core Allowed.

9. **Sections 314.2.1 is amended to read as follows:**

314.2.1 Condensate disposal. Condensate from all cooling coils and evaporators shall be conveyed from the drain pan outlet to an *approved* place of disposal... *{intervening text unchanged}* ... Condensate shall not discharge into a street, alley, sidewalk, rooftop, or other areas so as to cause a nuisance.

10. **Section 409.2 is amended to read as follows:**

409.2 Water connection. The water supply to a commercial dishwashing machine shall be protected against backflow by an air gap or backflow preventer in accordance with Section 608. *{remainder of section unchanged}*

11. **Section 413.4 is amended to read as follows:**

413.4 Required location for floor drains. Floor drains shall be installed in the following areas with trap primers as required:

1. In public coin-operated laundries and in the central washing facilities of multiple family dwellings, the rooms containing the automatic clothes washers shall be provided with floor drains located to readily drain the entire floor area. Such drains shall have a minimum outlet of not less than 3 inches (76 mm) in diameter.
2. Commercial kitchens. In lieu of floor drains in commercial kitchens, the code official may accept floor sinks.
3. Public restrooms.

12. **Section 502.3 is amended to read as follows:**

502.3 Water heaters installed in attics. Attics containing a water heater shall be provided ... *{intervening language unchanged}* ... side of the water heater. The clear access opening dimensions shall be a minimum 20 inches by 30 inches (508mm by 762 mm) or larger where such dimensions be not less than 20 inches by 30 inches (508mm by 762mm) where such dimensions are large enough to allow removal of the water heater. A walkway to the appliance shall be rated and approved by the building official, shall have continuous solid flooring with a minimum thickness of ½" plywood or 5/8" wafer board, and shall be placed over a load bearing wall or with engineered approval. As a minimum, for access to the attic space, provide one of the following:

1. A permanent stair.
2. A pull-down stair with a minimum 300 lbs. (136 kg) capacity.
3. An access door from an upper floor level.
4. Access Panel may be used in lieu of items 1, 2, and 3 with prior approval of the code official due to building conditions.

Exception: The passageway and level service space are not required where the appliance is capable of being serviced and removed through the required opening.

A receptacle outlet shall be provided at or near the equipment and appliance location within 25 feet and in accordance with the Electrical Code.

13. **Section 502 is amended by adding Section 502.6 to read as follows:**

502.6 Water heaters above ground or floor. When the attic, roof, mezzanine or platform in which a water heater is installed is more than eight (8) feet (2438 mm) above the ground or floor level, it shall be made accessible by a stairway or permanent ladder fastened to the building.

Exception: A max 10-gallon water heater (or larger with approval) is capable of being accessed through a lay-in ceiling and a water heater is installed is not more than ten (10) feet (3048 mm) above the ground or floor level and may be reached with a portable ladder.

14. **Section 504.6 is amended to read as follows:**

504.6 Requirements for discharge piping. The discharge piping serving a pressure relief valve, temperature relief valve or combination thereof shall:

1. Not be directly connected to the drainage system.
2. Discharge through an air gap fitting.
3. Not be smaller than the diameter of the outlet of the valve served and shall discharge full size to the air gap.
4. Serve a single relief device and shall not connect to piping serving any other relief device or equipment.

Exception: Multiple relief devices may be installed to a single T & P discharge piping system when *approved* by the administrative authority and permitted by the manufacturer's installation instructions and installed with those instructions.

5. Discharge to an indirect waste receptor or to the outdoors.
6. Discharge in a manner that does not cause personal injury or structural damage.
7. Discharge to a termination point that is already observable by the building occupants.
8. Not be trapped.
9. Be installed so as to flow by gravity.
10. Terminate not more than 6 inches above and not less than two times the discharge pipe diameter of the floor or flood level rim of the waste interceptor.
11. Not have a threaded connection at the end of such piping.
12. Not have valves or tee fittings.
13. Be constructed of those materials listed in Section 605.4 or materials tested, rated and approved for such use in accordance with ASME A112.4.1.
14. Be of nominal size larger than the size of the relief valve outlet, where the relief valve discharging piping is installed with insert fittings. The outlet end of such tubing shall be fastened in place.

15. **Section 504.7.1 is amended to read as follows:**

Section 504.7.1 Pan size and drain. The pan shall be not less than 1 ½ inches (38 mm) in depth and shall be of sufficient size and shape to receive all dripping or condensate from the tank or water heater. The pan shall be drained by an indirect waste pipe having a diameter of not less than ¾ inch (19 mm). Piping for safety pan drains shall be of those materials listed in Table 605.4. Multiple pan drains may

terminate to a single discharge piping system when approved by the administrative authority and permitted by the manufacturer's installation instructions and installed with those instructions.

16. **Section 605.3 is amended by adding a paragraph title "Exception" to read as follows:**

Exception: Where specific materials are required due to the special requirements such as a science lab or industrial use, then the specialty pipe required for that use will be permitted.

17. **Section 605.4 is amended by adding a paragraph title "Exception" to read as follows:**

Exception: Where specific materials are required due to the special requirements such as a science lab or industrial use, then the specialty pipe required for that use will be permitted.

18. **Section 605.5 is amended by adding a paragraph title "Exception" to read as follows:**

Exception: Where specific materials are required due to the special requirements such as a science lab or industrial use, then the specialty pipe fittings required for that use will be permitted.

19. **Section 606.1 is amended by deleting numbered paragraphs 4 and 5.**

20. **Section 608.1 is amended to read as follows:**

608.1 General. A potable water supply system shall be designed, installed and maintained in such a manner so as to prevent contamination from non-potable liquids, solids or gases being introduced into the potable water supply through cross-connections or any other piping connections to the system. Back flow preventer applications shall conform to applicable local regulations, Table 608.1, and as specifically stated in Sections 608.2 through 608.16.10.

21. **Section 608.17.5 change to read as follows:**

608.17.5 Connections to lawn irrigation systems. The potable water supply to lawn irrigation systems shall be protected against backflow by an atmospheric-type vacuum breaker, a pressure-type vacuum breaker, a double-check assembly or a reduced pressure principle backflow preventer. A valve shall not be installed downstream from an atmospheric vacuum breaker. Where chemicals are introduced into the system, the potable water supply shall be protected against backflow by a reduced pressure principle backflow preventer. All irrigation systems shall have rain and freeze protection installed.

22. **Section 608.18 is amended to read as follows:**

608.18 Protection of individual water supplies. An individual water supply shall be located and constructed so as to be safeguarded against contamination in accordance with applicable local regulations. Installation shall be in accordance with Sections 608.17.1 through 608.18.8.

23. **Section 702.1 is amended by adding a paragraph titled "Exception" to read as follows:**

Exception: Where specific materials are required due to the special requirements such as a science lab or industrial use, specialty pipe designed for that use will be permitted.

24. **Section 703.6 is deleted.**

25. **Section 704 is amended by adding Section 704.5 to read as follows:**

704.5 Single stack fittings. Single stack fittings with internal baffle, single stack shall be designed by a registered engineer and comply to a national recognized standard.

26. **Section 712 is amended by adding Section 712.5 to read as follows:**

712.5 Dual Pump System. All sumps shall be automatically discharged and, when in any “public use” occupancy where the sump serves more than 10 fixture units, shall be provided with dual pumps or ejectors arranged to function independently in case of overload or mechanical failure. For storm drainage sumps and pumping systems, see Section 1113.

27. **Sections 713 is amended by changing the title caption to read “ENGINEERED DRAINAGE DESIGN”.**

28. **Section 713.1 is amended to read as follows:**

714.1 Design of drainage system. The sizing requirements for plumbing drainage systems shall be determined by a registered professional engineering using approved design methods

29. **Section 803 is amended by adding Section 803.3 to read as follows:**

803.3.3 Special waste pipe, fittings and components. Pipes, fittings, and components receiving or intended to receive the discharge of any fixture into which acid or corrosive chemicals are placed shall be constructed of CPVC, high silicone iron, PP, PVDF, chemical resistant glass, or glazed ceramic materials.

30. **Section 903.1 is amended to read as follows:**

903.1 Roof extension. All open vent pipes that extend through a roof shall terminate not less than six (6) inches (152 mm) above the roof. Where the roof is to be used for assembly or as a promenade, observation deck, sunbathing deck or similar purposes, open vent pipes shall terminate not less than 7 feet (2134 mm) above the roof.

31. **Section 1002.10 is deleted.**

32. **Section 1003.3.4.1 is amended in its entirety (inclusive of deleting Table 1003.3.5.1) to read as follows:**

1003.3.4.1 Grease Interceptor Capacity. All food establishments having a food disposal or discharge of more than 50 gallons per minute shall discharge into a minimum 750 gallon grease trap. Establishments with a discharge of 50 gallons per minute or less shall discharge into at least a 100-pound size grease trap. An approved-type grease interceptor or grease trap complying with the provisions of this subsection shall be installed in the waste line leading from sinks, drains, and other fixtures or equipment in establishments such as restaurants, cafes, lunch counters, cafeterias, bars and clubs, hotels, hospitals, sanitarium, factory or school kitchens, or other establishments where grease may be introduced into the drainage or sewage system in quantities that can affect line stoppage or hinder sewage treatment or private sewage disposal when grease interceptors are required. All grease traps shall be located outside the building. A grease trap is not required for individual dwelling units or for any private living quarters.

1003.3.4.1.1 Grease Interceptors Minimum Specifications: Grease interceptors shall be constructed as a minimum as follows:

1. Concrete: Shall be composed of one part Portland cement and five parts aggregate. Reinforcement bars deformed number four bars on 18-inch centers.
2. Manholes: Cast iron frame with 20-inch cover.

3. Vents: Four-inch sanitary vent may be reduced to two inches if interceptor is connected to a properly vented sewer or waste line within 25 feet. Relief vents shall be two inches between compartments and to atmosphere above roof, and inside building.
4. Capacity: 750 gallons *retention* capacity or engineered
5. Clean out: Should be two-way located as near as possible to the interceptor on outflow line above seal.

33. **Section 1106.1 is amended to read as follows:**

1106.1 General. The size of the vertical conductors and leaders, building storm drains, building storm sewers, and any horizontal branches of such drains or sewers shall be based on six (6) inches per hour rainfall rate.

34. **Section 1108.3 is amended to read as follows:**

1108.3 Sizing of secondary drains. Secondary (emergency) roof drain systems shall be sized in accordance with Section 1106. Scuppers shall be sized to prevent the depth of ponding water from exceeding that for which the roof was designed as determined by Section 1101.7. Scuppers shall not have an opening dimension of less than 4 inches (102 mm). The flow through the primary system shall not be considered when sizing the secondary roof drainage system.

35. **Section 1109 is deleted.**

36. **Section 1202.1 is amended by deleting Exceptions 1 and 2.**

Sec. 3.09 Amendments to National Electrical Code, 2017 edition.

The following amendments to the National Electrical Code, 2017 edition, as adopted pursuant to Section 3.01, are hereby adopted.

1. **Article 90.4 is amended by adding section 90-4.1 to read as follows:**

Article 90-4.1 Administration and enforcement. Fees for the issuance of permits and performance of inspections as required by this code shall be as established from time to time by resolution of the City Council and set forth in the City’s Fee Schedule. There shall be a re-inspection fee, as set forth in the City’s Fee Schedule, where it is necessary for the electrical inspector to re-inspect any phase of an electrical job.

2. **Article 100, Part 1, is amended by adding the definitions of “Engineering Supervision” to read as follows:**

Engineering Supervision. Supervision by a Qualified State of Texas Licensed Professional Engineer engaged primarily in the design or maintenance of electrical installations.

3. **Article 110.2 is amended to read as follows:**

110.2 Approval. The conductors and equipment required or permitted by this *Code* shall be acceptable only if approved. Approval of equipment may be evident by listing and labeling of equipment by a Nationally Recognized Testing Lab (NRTL) with a certification mark of that laboratory or a qualified third-party inspection agency approved by the AHJ.

Exception: Unlisted equipment that is relocated to another location within a jurisdiction or is field modified is subject to the approval by the AHJ. This approval may be by a field evaluation by a NRTL or qualified third-party inspection agency approved by the AHJ.

Informational Note No. 1: See 90.7, Examination of Equipment for Safety, and 110.3, Examination, Identification, Installation, and Use of Equipment. See definitions of Approved, Identified, Labeled, and Listed.

Informational Note No. 2: Manufacturer's self-certification of equipment may not necessarily comply with US product safety standards as certified by a Nationally Recognized Testing Lab.

Informational Note No. 3: NFPA 790 and 791 provide an example of an approved method for qualifying a third-party inspection agency.

4. **Article 210.52(G)(1) is amended to read as followed:**

(1) **Garages.** In each attached garage and in each detached garage with electric power, at least one receptacle outlet shall be installed for each car space.

5. **Article 300.1(A) is amended to read as follows:**

(A) **All Wiring Installations.** This Article covers general questions requirements for wiring methods and materials for all wiring installations unless modified by other articles. All electrical conductors for commercial, office, or industrial installation shall be installed in approved conduits or raceways, regardless of type of construction.

(1) No electrical panels or plastic electrical boxes shall be mounted on the opposite sides of the walls around bath tubs and shower enclosures, and Romex in such locations shall be enclosed in metal conduit around bath areas.

(2) Smoke detectors (alarms), carbon monoxide alarms, GFCI and AFI protection shall be updated at time of service upgrade or remodel.

(3) All commercial structures that are framed in wood material shall be wired in either MC cable or conduit.

6. **Article 300.11 is amended by adding Paragraph (E) to read as follows:**

(D) All ceiling grid lights shall be supported to structural framing of the building and not to the grid into which they are laid.

7. **Article 330.1 is amended to read as follows:**

330.1 Scope. This article covers the use, installation, and construction specifications of metal-clad cable, Type MC. All metal clad cable installations shall install insulated bushings such as red devils.

8. **Article 500.8 (A)(3) is amended to read as follows:**

(3) Evidence acceptable to the authority having jurisdiction such as a manufacturer's self-evaluation or an engineering judgment signed and sealed by a qualified licensed Professional Engineer in the State of Texas.

9. **Article 505.7 (A) is amended to read as follows:**

(A) Implementation of Zone Classification System. Classification of areas, engineering and design, selection of equipment and wiring methods, installation, and inspection shall be performed by a qualified licensed Professional Engineer in the State of Texas.

10. **Article 517.30(G) is amended to read as follows:**

(G) Coordination. Overcurrent protection devices serving the equipment branch of the essential electrical system shall be coordinated for the period of time that a fault's duration extends beyond 0.1 second.

Exception No. 1: Between transformer primary and secondary overcurrent protective devices, where only one overcurrent protective device or set of overcurrent protective devices exists on the transformer secondary.

Exception No. 2: Between overcurrent protective devices of the same size (ampere rating) in series.

Informational Note: The terms coordination and coordinated as used in this section do not cover the full range of overcurrent conditions.

11. **Article 600.6(A) (1) is amended by amending the Exceptions to read as follows:**

Exception No.1: A disconnect shall not be required for branch circuits(s) or feeder conductor(s) passing through the sign where enclosed in a Chapter 3 listed raceway or metal-jacketed cable identified for the location. The conductor(s) shall not serve the sign body or sign enclosure where passing through.

Exception No. 2. A disconnect shall not be required at the point of entry to a sign body, sign enclosure, or pole for branch circuit conductor(s). The conductors shall be enclosed in a Chapter 3 listed raceway or metal-jacketed cable identified for the location. The conductor(s) shall be routed to a device box which contains the disconnect. A field-applied permanent warning label that is visible during servicing shall be applied to the raceway at or near the point of entry into the sign enclosure or sign body. The warning label shall comply with 110.21(B) and state the following: "Danger. This raceway contains energized conductors." The marking shall include the location of the disconnecting means for the energized conductor(s). The disconnecting means shall be capable of being locked in the open position in accordance with 110.25.

Exception No. 3: A disconnect shall not be required at the point of entry to a sign enclosure or sign body for branch circuit(s) or feeder conductor(s) that supply an internal panelboard(s) in a sign enclosure or sign body. The conductors shall be enclosed in a Chapter 3 listed raceway or metal-jacketed cable identified for the location. A field-applied permanent warning label that is visible during servicing shall be applied to the raceway at or near the point of entry into the sign enclosure or sign body. The warning label shall comply with 110.21(B) and state the following: "Danger. This raceway contains energized conductors." The marking shall include the location of the disconnecting means for the energized conductor(s). The disconnecting means shall be capable of being locked in the open position in accordance with 110.25.

12. **Article 700 is amended by adding Article 700. 27 to read as follows:**

Article 700. 27 Wiring of Emergency Light Fixtures and Locations.

(1) Battery pack fixtures must be wired to the normal lighting circuit where they are installed. The battery pack shall be tied onto the hot leg of the room switch. Where room switches are not

provided and lights are turned off at the breaker switch, it shall be necessary to provide a light switch at the breaker control panel, wiring the fixtures as previously described. Permanent identification of a RED circular mark at the breaker located in the electrical panel box.

- (2) Where battery pack florescent fixtures are installed on a security light circuit which remains on at all times, it is not necessary to wire through a control switch provided the breaker is locked in the on position. All other installations shall be wired in the same manner as battery pack incandescent fixtures.
- (3) Where large open areas are lighted with two or more circuits, it shall be necessary to wire each emergency light fixture to the nearest lighting circuit.
- (4) All bathrooms including male, female and family. Also all Fire Riser and Command Rooms.
- (5) All Emergency and Exit Lights shall be installed according to the drawings and shall be field verified meeting all code requirements and additional lighting may be required.

Sec. 3.10. Amendments to International Energy Conservation Code, 2018 edition.

The following amendments to the International Energy Conservation Code, 2018 edition, as adopted pursuant to Section 3.01, are hereby adopted:

1. **Section C102/R102 is amended by adding Section C102.1.2 and Section R102.1.2 to read as follows:**

C102.1.2 Alternative compliance. A building certified by a national, state, or local accredited energy efficiency program and determined by the Energy Systems Laboratory to be in compliance with the energy efficiency requirements of this section may, at the option of the code official, be considered in compliance. The United States Environmental Protection Agency's Energy Star Program certification energy code equivalency shall be considered in compliance.

R102.1.2 (N1101.4.1) Alternative compliance. A building certified by a national, state, or local accredited energy efficiency program and determined by the Energy Systems Laboratory to be in compliance with the energy efficiency requirements of this section may, at the option of the code official, be considered in compliance. The United States Environmental Protection Agency's Energy Star Program certification energy code equivalency shall be considered in compliance. Regardless of the program or the path to compliance, each 1- and 2-family dwelling shall be tested for air and duct leakage as prescribed in Section R402.4 and R403.3.3 respectively.

2. **Section R202 (N1101.6) is amended by adding a definition for the phrases "Dynamic Glazing" and "Projection Factor" to read as follows:**

DYNAMIC GLAZING. Any fenestration product that has the fully reversible ability to change its performance properties, including U-factor, solar heat gain coefficient (SHGC), or visible transmittance (VT).

PROJECTION FACTOR. The ration of the horizontal depth of the overhang, eve or permanently attached shading device, divided by the distance measured vertically from the bottom of the fenestration glazing to the underside of the overhang, eave or permanently attached shading device.

3. **Table R402.1.2 is amended by changing the WOOD FRAME WALL R-VALUE for CLIMATE ZONE 3 to read "13".**

4. **Table R402.1.4 is amend by changing the WOOD FRAME WALL U-FACTOR for CLIMATE ZONE 3 to read “0.082”.**
5. **Table R402.1.2 (N1102.1.2) in Section R402.1.2 is amended by amending the Fenestration U-factor for Climate Zone 3 to read “0.35”.**
6. **Table R402.1.4 (N1102.1.4) in Section R402.1.4 is amended by amending the Fenestration U-factor for Climate Zone 3 to read “0.35”.**
7. **Section C402.2/R402.2 is amended by adding Sections C402.2.6 /R402.2.14 to read as follows:**

Section C402.2.6/R402.2.14 Insulation installed in walls. To ensure that insulation remains in place, insulation installed in walls shall be totally enclosed on all sides consisting of framing lumber, gypsum, sheathing, wood structural panel sheathing, netting or other equivalent material approved by the building official.

8. **Section R402.3.2 (N1102.3.2) is amend by adding a paragraph and table following the exception to read as follows:**

...Where vertical fenestration is shaded by an overhang, eave, or permanently attached shading device, the SHGC required in Table R402.1.2 shall be reduced by using the multipliers in Table R402.3.2 SHGC Multipliers for Permanent Projections.

Projection Factor	SHGC Multiplier (all Other Orientation)	SHGC Multiplier (North Oriented)
0 - 0.10	1.00	1.00
>0.10 – 0.20	0.91	0.95
>0.20 – 0.30	0.82	0.91
>0.30 – 0.40	0.74	0.87
>0.40 – 0.50	0.67	0.84
>0.50 – 0.60	0.61	0.81
>0.60 – 0.70	0.56	0.78
>0.70 – 0.80	0.51	0.76
>0.80 – 0.90	0.47	0.75
>0.90 – 1.00	0.44	0.73

9. **Section R402.4.1.2(N1102.4.1.2) is amended by amending the first sentence to read as follows:**

R402.4.1.2 Testing. The building or dwelling unit shall be tested and verified as having an air leakage rate of not exceeding 5 air changes per hour in Climate Zone 3. *{Remainder of text unchanged}*.
10. **Section R402.4.1.2 (N1102.4.1.2) is further amended by adding the following paragraph:**

Mandatory testing shall only be performed by individuals that are certified to perform air infiltration testing certified by national or state organizations as approved by the building official. The certified individuals must be an independent third-party entity and may not be employed, or have any financial interest in, the company that constructs the structure.
11. **Section R402.4.1 (N1102.4) is amended by adding Section 402.4.1.3 (N1102.4.1.3) and table to read as follows:**

R402.4.1.3 (N1102.4.1.3) Testing option – ACH tradeoff. As an option to the air leakage rate set out in Section R402.4.1.2 (N1102.4.1.2), 1- and 2-family homes meeting all of the listed criteria below and the *thermal envelope* requirements in Table R402.4.1.3 (N1102.4.1.3) will be considered compliant when tested and verified as having an air leakage rate to not less than or equal to four air changes per hour when tested and reported in accordance with the testing standards and reporting criteria listed in Section R402.4.1.2 (N1102.4.1.2).

The compliance equivalency is limited as follows:

1. Limited to a conditioned floor area between 1,000 and 6,000 square feet,
2. Limited to between 2 to 6 bedrooms,
3. Assumes all ductwork and mechanical equipment is located in the unconditioned attic,
4. Assumes typical wood framing in the walls and roof, and
5. Assumes one of the following heating/cooling systems:
 - a. All electric system with a heat pump for heating, or
 - b. A system with electric cooling and natural gas heating.

Dwellings using electric resistance strip heating do not qualify for this tradeoff.

TABLE R402.4.1.3 (N1102.4.1.3)^a

Envelope Component	Option #1	Option #2
R402.4 Air Leakage	≤ 4 ACH50	≤ 4 ACH50
Wall Insulation <i>R</i> -value	R13 + R3 ^b	R13 + R3 ^b
Fenestration <i>U</i> -factor	≤ 0.32	≤ 0.32
Fenestration SHGC	≤ 0.25	≤ 0.25
Ceiling <i>R</i> -value	≥ R49	≥ R49
Duct Insulation <i>R</i> -value	R8	R6
Radiant Barrier Required	No	Yes

^a Except for the values listed in the table, all other mandatory code provisions are applicable.

^b The first value listed is the *R*-value of cavity insulation, the second value is the *R*-value of the continuous insulation or insulated siding.

12. **Section R402.4 is amended by adding Sections R402.4.1.4 and R402.4.1.5 to read as follows:**

R402.4.1.4 Testing options for R2 multifamily dwelling units. As an option to the air leakage rate set out in Section R402.4.1.2, multifamily dwelling units will be considered compliant when tested and verified as having an air leakage rate to the air leakage rate set out in either Section R402.4.1.4.1 or Section R402.4.1.4.2 when tested and reported in accordance with the testing standards and reporting criteria listed in Section R402.4.1.2

R402.4.1.4.1 Total air leakage rate for interior multifamily dwelling units. Interior multifamily dwelling units with a measured, “unguarded” total air leakage result of 5.3 ACH50 or less shall be considered compliant.

R402.4.1.4.2 Total air leakage rate for corner multifamily dwelling units. Corner multifamily units with a measured, “unguarded” total leakage result of less than 5.0 ACH50 shall be considered compliant.

R402.4.1.5 Sampling options for R2 multifamily dwelling units. For buildings having three or more dwelling units, a minimum of 15% of the dwelling units in each building must be tested as required by Section R402.4.1.2. Prior to beginning sampling for testing, “Initial Testing” is required for each multifamily property. “Initial Testing” shall consist of the 3rd party testing contractor performing the required tests on at least three consecutive dwelling units. Test results from the “Initial Testing” must satisfy minimum code requirements before sampling is permitted. Dwelling units selected for the “Initial Testing” must be within the same building. Dwelling units selected for “Initial Testing” shall not be included in a “sample group” or counted toward the minimum 15% of dwelling units tested. The building official shall randomly select the three dwelling units for “Initial Testing.” The building official may delegate the random selection to the designated 3rd party testing contractor.

R402.4.1.5.1 Sample group Identification and Sampling. The builder shall identify a "sample group" which may be a building, floor, fire area or portion thereof. All of the dwelling units within the “sample group” must be at the same stage of construction and must be ready for testing. The building official shall randomly select at least 15% of dwelling units from each “sample group” for testing. The building official may delegate the random selection to the designated 3rd party testing contractor.

If each tested dwelling unit within a “sample group” meets the minimum code requirements, then all dwelling units in the “sample group” are considered to meet the minimum code requirements.

Before a building may be deemed compliant with the testing as required, each “sample group” must be deemed compliant with the minimum code requirements. The sum total of all of the tested dwelling units across all “sample groups” shall not be less than a minimum of 15% of the dwelling units in a building.

R402.4.1.5.2 Failure to Meet Code Requirement(s). If any dwelling units within the identified “sample group” fail to meet a code requirement as determined by testing, the builder will be directed to correct the cause(s) of failure, and 30% of the remaining dwelling units in the “sample group” will be randomly selected for testing by the building official, or third-party testing contractor, regarding the specific cause(s) of failure.

If any failures occur in the additional dwelling units, all remaining dwelling units in the sample group must be individually tested for code compliance.

A multifamily property with three failures within a 90-day period is no longer eligible to use the sampling protocol in that community or project until successfully repeating "Initial Testing." Sampling may be reinstated after at least three consecutive dwelling units are individually verified to meet all code requirements.

A Certificate of Occupancy may not may be issued for any building until testing has been performed and deemed to satisfy the minimum code requirements on the dwelling unit(s) identified for testing.

13. **Section R403.3.3 (N1103.3.3) is amended by adding the following to the end of the section:**

Mandatory testing shall only be performed by individuals that are certified to perform duct testing leakage testing certified by national or state organizations as approved by the building official. The certified individuals must be an independent third-party entity, and may not be employed, or have any financial interest in the company that constructs the structure.

14. **Section R403.3.4 is amended by adding Section R403.3.4.1 to read as follows:**

R403.3.4.1 Sampling options for R2 multifamily dwelling units. For buildings having three or more dwelling units, a minimum of 15% of the dwelling units in each building must be tested as required by Section R403.3.3. Prior to beginning sampling for testing, “Initial Testing” is required for each multifamily property. “Initial Testing” shall consist of the 3rd party testing contractor performing the required tests on at least three consecutive dwelling units. Test results from the “Initial Testing” must satisfy minimum code requirements before sampling is permitted. Dwelling units selected for the “Initial Testing” must be within the same building. Dwelling units selected for “Initial Testing” shall not be included in a “sample group” or counted toward the minimum 15% of dwelling units tested. The building official shall randomly select the three dwelling units for “Initial Testing.” The building official may delegate the random selection to the designated 3rd party testing contractor.

R403.3.4.1.1 Sample group Identification and Sampling. The builder shall identify a "sample group" which may be a building, floor, fire area or portion thereof. All of the dwelling units within the “sample group” must be at the same stage of construction and must be ready for testing. The building official shall randomly select at least 15% of dwelling units from each “sample group” for testing. The building official may delegate the random selection to the designated 3rd party testing contractor.

If each tested dwelling unit within a “sample group” meets the minimum code requirements, then all dwelling units in the “sample group” are considered to meet the minimum code requirements.

Before a building may be deemed compliant with the testing as required, each “sample group” must be deemed compliant with the minimum code requirements. The sum total of all of the tested dwelling units across all “sample groups” shall not be less than a minimum of 15% of the dwelling units in a building.

R403.3.4.1.2 Failure to Meet Code Requirement(s). If any dwelling units within the identified “sample group” fail to meet a code requirement as determined by testing, the builder will be directed to correct the cause(s) of failure, and 30% of the remaining dwelling units in the “sample group” will be randomly selected for testing by the building official, or third-party testing contractor, regarding the specific cause(s) of failure.

If any failures occur in the additional dwelling units, all remaining dwelling units in the sample group must be individually tested for code compliance.

A multifamily property with three failures within a 90-day period is no longer eligible to use the sampling protocol in that community or project until successfully repeating "Initial Testing." Sampling may be reinstated after at least three consecutive dwelling units are individually verified to meet all code requirements.

A Certificate of Occupancy may not be issued for any building until testing has been performed and deemed to satisfy the minimum code requirements on the dwelling unit(s) identified for testing.

15. **Section C402.2/R402.2 (N1102.2) is amended by adding Section C402.2.8/R402.2.14 (N1102.2.14) to read as follows:**

Section C402.2.8/R402.2.14 (N1102.2.14) Insulation installed in walls. Insulation installed in walls shall be totally enclosed on all sides consisting of framing lumber, gypsum, sheathing, wood structural panel sheathing or other equivalent material approved by the building official.

16. **Section C403.7.4 is amended by adding Exception #12 to read as follows:**

12. Individual ventilation systems that serve an individual dwelling unit or sleeping unit.

17. **Section C403.11.1 is amended by adding the following:**

Environmental ducts and plenums installed in vertical chases, both supply and exhaust, where the ducts or plenums will not be accessible after construction completion, shall be leak tested in accordance with the SMACNA HVAC Air Leakage Test Manual to the installed ductwork class and pressure requirements.

Documentation shall be furnished demonstrating that representative sections totaling not less than 25 percent of the duct area have been tested and that all tested sections comply with the requirements of this section.

18. **Section R404.1 (N1104.1) is amended to read in its entirety as follows:**

Section R404.1 (N1104.1) Lighting equipment (Mandatory). Not less than 75 percent of the lamps in permanently installed lighting fixtures or not less than 75 percent of the permanently installed lighting fixtures shall contain only high-efficacy lamps.

19. **Section 405.2 (N1105.2) is amended by adding the Exceptions to read as follows:**

Exceptions:

1. For one and two family dwellings the maximum envelope leakage of 4 ACH50 is permitted provided the envelope leakage in the Standard Reference Design is 3 ACH50 and all other requirements of Section R405 are met, including all other mandatory measures. The annual energy cost or source energy usage of the Proposed Design must be equal to or less than that of the Standard Reference Design.
2. For multifamily or townhomes and buildings classified as Group R2 and Group R4 of three stories or less the maximum envelope leakage of less than 5 ACH50 is permitted provided the envelope leakage in the Standard Reference Design is 3 ACH50 and all other requirements of Section R405 are met, including all other mandatory measures. The annual energy cost or source energy usage of the Proposed Design must be equal to or less than that of the Standard Reference Design.

20. **Section R405.6.2 is amended by adding the following to the end of section:**

Acceptable performance software simulation tools may include, but are not limited to, REM Rate™, Energy Gauge and IC3. Other performance software programs accredited by RESNET BESTEST and having the ability to provide a report as outlined in R405.4.2 may also be deemed acceptable performance simulation programs and may be considered by the building official.

21. **Section C405.9 is deleted.**

22. **Table R406.4 Maximum Energy Rating Index is amended to read as follows:**

Table R406.4¹
Maximum Energy Rating Index

Climate Zone	Energy Rating Index
3	65

¹ This table is effective until August 31, 2019.

Table R406.4²
Maximum Energy Rating Index

Climate Zone	Energy Rating Index
3	63

² This table is effective from September 1, 2019 to August 31, 2022.

Table R406.4³
Maximum Energy Rating Index

Climate Zone	Energy Rating Index
3	59

³ This table is effective on or after September 1, 2022.

23. **Section C408.3.1 is amended to read as follows:**

C408.3.1 Functional Testing. Prior to passing final inspection, the *registered design professional* or approved agency shall provide evidence that the lighting control systems have been tested to ensure that control hardware and software are calibrated, adjusted, programmed, and in proper working condition in accordance with the construction documents and manufacturer’s instructions. Functional testing shall be in accordance with Sections C408.3.1.1 through C408.3.1.3 for the applicable control type.

Sec. 3.10. - Contractor annual registration.

(a) *Annual registration; fee.* The following people or business entities shall register with the community development department on a form provided by the city and pay an annual registration fee established by the city council pursuant to section 1.09 of this Code:

- (1) Any person or entity making application for a permit from the city which must be issued prior to commencement of any work regulated by article III of this Code;
- (2) Code-certified inspectors certified pursuant to V.T.C.A., Health and Safety Code Ch. 388 who is performing inspections of and providing to the city certifications regarding the compliance of buildings and other structures with the latest edition of the International Energy Conservation Code adopted and amended as part of article III of this Code; and
- (3) Any person who is a certified backflow assembly tester who performs inspections of backflow prevention assemblies within the city pursuant to section 14-14(b)(3) of the Code of Ordinances.

(b) *Exemptions from registration.* The following shall be exempt from subsection (a) of this section:

- (1) A person who performs work solely on property owned or leased by the person; and

- (2) A person who is an employee of the owner or lessee of property who performs work solely on the property owned or leased by the person's employer. The exemption from registration provided by this subsection (b) does not exempt any person for any requirement to obtain any license or permit or the payment of any license or permit fee required by this Code or the Code of Ordinances prior to commence of any work for which a permit or license must be obtained or performance of an inspection for which a fee must be paid.
- (c) *Exemption from fee.* A person or entity is exempt from payment of the registration fee required by subsection (a) of this section to the extent state law prohibits the city from assessing a registration fee from such person or entity; provided, however, such person or entity shall not be exempt from registering with the city as required by subsection (a) of this section except as allowed pursuant to subsection (b) of this section.
- (d) *No permit/license without registration.* No license or permit for which an application is made will be issued to, or inspection report accepted from a person or entity that has not registered and paid the required fee pursuant to this section.

SECTION 2. All ordinances of the City of Allen in conflict with the provisions of this Ordinance shall be, and the same are hereby, repealed; provided, however, that all other provisions of said Ordinances not in conflict herewith shall remain in full force and effect.

SECTION 3. Should any word, sentence, paragraph, subdivision, clause, phrase or section of this Ordinance, or of the Allen Land Development Code, as amended hereby, be adjudged or held to be void or unconstitutional, the same shall not affect the validity of the remaining portions of said Ordinance or the Allen Land Development Code, as amended hereby, which shall remain in full force and effect.

SECTION 4. An offense committed before the effective date of this Ordinance is governed by prior law and the provisions of the Allen Land Development Code, as amended, in effect when the offense was committed and the former law is continued in effect for this purpose.

SECTION 5. Any person, firm or corporation violating any of the provisions or terms of this Ordinance shall be subject to the same penalty as provided for in Allen Land Development Code of the City of Allen, as previously amended, and upon conviction shall be punished by a fine not to exceed the sum of Two Thousand Dollars (\$2,000) for each offense, and each and every day such violation shall continue shall be deemed to constitute a separate offense.

SECTION 7. Section 1 of this Ordinance shall take effect on September 1, 2019, after its passage and publication in accordance with the provisions of the Charter of the City of Allen. All remaining sections of this Ordinance shall take effect immediately from and after its passage and publication in accordance with the provisions of the Charter of the City of Allen, and it is accordingly so ordained.

DULY PASSED AND APPROVED BY THE CITY COUNCIL OF THE CITY OF ALLEN, COLLIN COUNTY, TEXAS, ON THIS THE 27TH DAY OF AUGUST 2019.

APPROVED:

Stephen Terrell, MAYOR

APPROVED AS TO FORM:

ATTEST:

Peter G. Smith, CITY ATTORNEY
(kbl:8/1/19:109762)

Shelley B. George, TRMC, CITY SECRETARY